

University of Rochester Solar Splash

Boat #9

Technical Report

April 29th, 2024

Team Members

Calista Courtney · Alejandro Porras Dias · Will Knoff

Advisors

LT Vincent Kindfuller · Kyle DeManincor · Jim Alkins · Chris Muir

Executive Summary

The year 2024 marks the first competition post-COVID-19 pandemic that the University of Rochester team was able to reignite our Solar Splash club and produce a functioning boat. Although we tried to compete last year, there were several obstacles. To streamline getting back to competition, we build around the 2019 setup. We reused expensive equipment and followed similar circuits but had to revamp it to ensure functionality and modernization. For example, internal structures, like the hull, are different and built with wood. Reusing previous work helped save time and money. Our budget was cut in half after we needed help. We needed help to buy newer equipment.

Our propeller project aims to design, simulate, manufacture, and test a toroidal propeller for the endurance race, aiming for significantly improved efficiency compared to the current propeller. The current propeller's efficiency needs to meet the requirements for optimal performance, posing a challenge for the upcoming competition on June 4th. We aim to devise a propeller solution that maximizes efficiency, bolstering the team's competitive edge in the Solar Splash endurance event.

Last year, we faced a tough challenge while designing a new boat. It turned out to be more complicated than expected, and we changed our approach. Instead of building a new hull from scratch, we refurbished an old one. This shift came with difficulties and required significant time and money. We encountered unexpected problems and had to absorb some initial costs. Despite the initial setbacks, our team persisted and collectively reevaluated our goals and strategies. This led us to the right path. As we refurbish the 2019 previously used boat, we've overcome challenges and gained valuable insights for a more efficient approach. We can reference their tech report and see their regrets. We are adapting and re-innovating. Although the process involved some wasted time and money, our current progress indicates that we're heading in the right direction, with lessons learned from overcoming obstacles.

Since we recruited many more team members, we can ensure our club's longevity and ability to dedicate time outside engineering work. Our organization actively engages with UR departments and the Greater Rochester community through volunteering in events like STEM Initiative Day of Science and the Engineering Open House. During the Day of Science, local schools explore science through interactive exhibits and experiments. We contribute by organizing engaging activities, including incorporating boats into our station, to spark interest in STEM fields. We also volunteer at the Engineering Open House, which allows us to showcase our work and actively share our enthusiasm for science and engineering with students, including those considering the University of Rochester for their education. Through these interactions, we seek to establish meaningful connections between our organization, the University of Rochester, and the local community, contributing to the broader promotion of science education and inspiring the next generation of students to pursue STEM disciplines.

We are very proud of the University of Rochester Solar Splash team's work this year. We've made significant progress in our engineering work, involvement in our campus community, and overall mission of racing a successful boat at the Solar Splash competition. We look forward to the competition!

Table of Contents

Executive Summary	2
Table of Contents	3
I. Overall Project Objectives	6
II. Data Acquisition and Communication	7
A. Current Design	7
B. Analysis of Design Concepts	8
C. Design Testing and Evaluation	8
III. Electrical System	9
A. Current Design	9
B. Analysis of Design Concepts	9
C. Design Testing and Evaluation	9
IV. Power Electronics System	10
A. Past Configuration	10
B. New Configuration	11
C. Power Budget	12
V. Drivetrain and Steering	12
A. Drivetrain	12
B. Propellers	15
C. Steering System	17
VI. Solar Energy System	18
A. Solar Panels	18
B. Solar Chargers	20
VII. Hull Design	21
A. Hull Design History	21
B. Analysis of Design Concepts	22
C. Design Testing and Evaluation	23
VIII. Project Management	24
A. Team Members and Leadership Roles	24
B. Project Planning and Schedule	24
C. Financing and Fundraising	25
D. Strategy for Team Continuity and Sustainability	25
E. Discussion and Self-Evaluation	26
IX. Conclusions and Recommendations	26
A. Strengths	26
B. Weaknesses	26

C. Lessons Learned.	26
D. Achievement of Objectives	26
E. Future Objectives	27
References	28
Appendix A: Battery Documentation	29
A. Material Safety Data Sheets	29
B. Battery Datasheets	35
Appendix B: Flotation Calculations	38
Appendix C: Proof of Insurance	40
Appendix D: Team Roster	41
A. Undergraduate Roster	41
B. Advisor Roster	41
Appendix E: Telemetry Data	42
A. Description of Telemetry Protocol	42
Node Implementation	43
C. Telemetry Node Data	44
Appendix F: Electrical System Data	45
Appendix G: Power Electronics Data	46
A. Motor Specs	46
B. Motor Controllers	46
C. Motor Datasheets	47
D. Notes on Alltrax Throttle Control	50
Appendix H: Drivetrain and Steering Data	51
A. Torqeedo Propeller Datasheets	51
B. Drivetrain CAD Drawings	52
C. Lower Unit Modifications	57
Appendix I: Solar Energy System Data	58
A. Solar Charger Datasheets	58
B. Solar Panel Datasheets	59
C. Explanation of Step-Down vs. Boost MPPT Chargers	60
Appendix J: Hull Design Data	62
A. Hull Modification Process	62
B. Hull Design History	64
C. Hydrostatics Testing Program	65
Appendix K: Project Management Data	68
A. Executive Board Roles	68
B. Budgeting Documentation	68

Appendix L: Power Budget	69
Appendix M: Propeller Data	71
A. Validating Testing Methods	71
B. Simulation Results	72
C. Modeling and Optimization	73

I. Overall Project Objectives

Our objectives for this year focused on our drivetrain and modeling boat components. We identified several objectives in each area, which we worked on throughout the year.

We had the following goals in mind for our drivetrain:

- **Purchase new batteries compatible with all events:** Previously, we had a set of batteries for sprint and endurance. However, both sets were deemed unusable. As the batteries sat, the batteries self-discharged. The budget was portioned to purchase new batteries. Our budget cuts from previous years prevent purchases of different battery sets. A new project arose from needing to find batteries that would perform well in all events. The new batteries have a different amperage than the past years. We needed to adapt our drivetrain and update the power budget.
- **Solar Panels with new rule change:** In our team's last competition, there was a 480W limit on panels, which has now been set to 720W. Further, the solar arrangement must now remain the same for all events. Since a tracking solar stand could not be used, this left the team with the task of using the best panel configuration to maximize power received while keeping the design ideal for all events by balancing aerodynamics and optimal position to the sun. Additionally, with panels laying flat, we wished to explore a design utilizing hinges to easily access electronics beneath the panels.

In the boat modeling area, we built on the work we started in the 2019 year:

- **Refurbishing the hull:** The Great Canadian hull was used in the 2019 competition. Since then, the club has tried to build its own hull from scratch. Unfortunately, the 2023 season did not produce a new hull. Instead, the Great Canadian hull was reused. A big obstacle was that the hull was left outside. There was necessary clean-up, re-exposing, and repainting to get the hull to a cleaner, usable state.
- **CAD Modeling:** After confirming the 2019 hull as our hull, we utilized Fusion 360 software to create a detailed CAD model. This allowed us to make precise adjustments to optimize the hull's center of mass. With the hull completed, we focused on designing the internal framework and mechanisms for weight displacement. CAD modeling was essential throughout, providing valuable insights into aerodynamics, structure, and weight distribution, ultimately improving the overall performance of our design.
- **New Propeller Design:** We decided to research and create our endurance propeller based on the toroidal propeller from MIT. We could model the current and newly designed toroidal propellers using NX. Then, Star CCM+ was utilized for the CFD testing. We also 3D-printed the toroidal propeller. Then, we tested the toroidal and current propeller in a water tank. Our goal was to see an increase in torque efficiency, and we hope to use a computer numerical control (CNC) machine to produce a robust, functional design.

Our team's main objective was restoring functionality to old systems. Pursuing this goal has resparked our club's participation in the competition. We are a well-known engineering club on campus and have increased membership interest. Our team understands the systems and can work on upgrading specifics next year. The club has longevity with committed students!

II. Data Acquisition and Communication

A. Current Design

The current design of the data acquisition and communications system (the “telemetry” system) is the cumulative result of previous years’ work. The telemetry system is at the center of the data and control of the boat. It consists of several parts:

- **Telemetry Server:** This central hub aggregates sensor values, stores, and transmits these values.
- **Telemetry Protocol:** The communication method(s) used to pass data between the telemetry server and sensors.
- **Telemetry Sensor Nodes:** These computational nodes collect data from related sensors and transmit packed binary data to the telemetry server.
- **Telemetry Monitoring UI:** Software, both on the boat and onshore, for monitoring and analysis of the recorded data.

At the center of the boat’s telemetry system is a Raspberry Pi, functioning as the telemetry server. It is responsible for managing USB connections to devices. Fig. 1 is a schematic of the server containing telemetry devices on the boat. The server constantly scans USB ports for devices and connects to sensor nodes around the boat, decoding, aggregating, and interpreting all the data sent to it. In addition, the server is set up with a 433Mhz radio transceiver used to stream all data back to the shore for remote analysis.

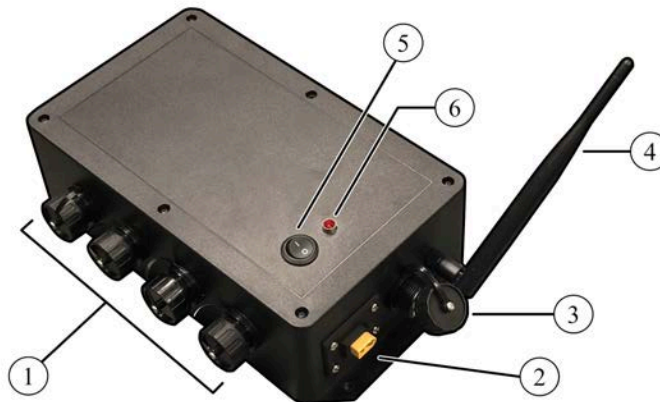

Figure 1: The Telemetry Server unit is the hub for all telemetry devices in the boat. ① Waterproof USB plugs ② Power Input ③ HDMI Output ④ 433Mhz Radio Antenna ⑤ Power Switch ⑥ Status LED

The server communicates with sensor nodes using a protocol designed by our team, the Telemetry Protocol. The system was designed to be extremely lightweight, allowing for transmitting a large amount of sensor data in minimal space. For more information about the Telemetry Protocol, please see *Appendix E: Telemetry Data*.

In addition, the Telemetry UI provides an application for human-readable viewing and processing of the boat’s data. An instance of the Telemetry UI could be used both on the boat dashboard and on a shore computer. However, the previous team opted to use an older,

less-featured Telemetry Dashboard instead of the improved Telemetry UI on-board due to limitations in the processing power of the on-board Raspberry Pi.

B. Analysis of Design Concepts

In the past, the team has used either an Arduino microcontroller or a Raspberry Pi. We continued using a Raspberry Pi as the main telemetry server board. This provides advantages over Arduino, like having access to multiprocessing and a scheduler, which come from having an operating system.

The Telemetry team initially discussed rewriting the system in Go for improved performance, ease of deployment, and developer experience. However, with limited knowledge and noting that the foundations of the current telemetry system worked and continue to work well, the team opted to keep it the same. Instead, the team worked on getting the system up and running.

A large amount of work went into learning the old system, which was disassembled for improvements and never put back together. We had to reverse engineer the system's working to get it in a working state. The team worked on learning the control flow and design decisions, which were made in tandem with the electrical system and thus required cross-team collaboration. Fig. 2 shows the team's progress on displaying information.

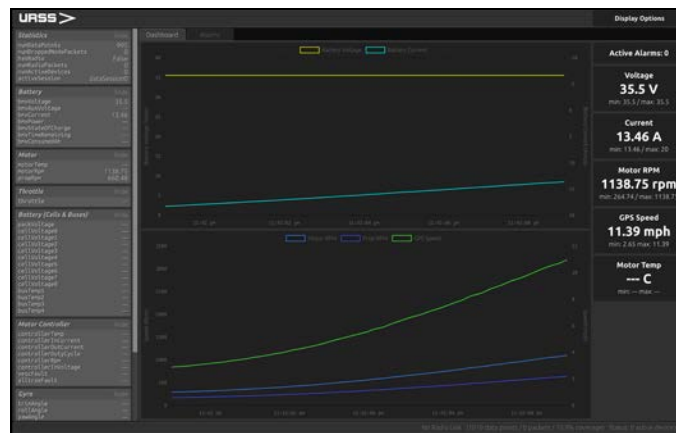

Figure 2: Telemetry UI interface, with charts showing various boat data.

Though this took up the majority of our time, we were able to make one improvement to the system. The Telemetry UI was previously an extensive Electron application unusable onboard due to the Raspberry Pi's hardware-limited performance. While we still chose not to use it onboard, we spent some time rewriting the UI in a Go application using Wails to improve the performance of the app greatly.

C. Design Testing and Evaluation

While we were able to get the system running, we had to limit its capabilities due to time constraints. We were unable to include the following Nodes: GPS/IMU, which could provide real-time speed and acceleration values; Alltrax Motor Controller, which could give digital throttle control for the spring race; and Battery/Cell Voltages, which would provide helpful battery diagnostics. We should rebuild/build telemetry nodes for this data in the future.

Additionally, the team needed help getting the system running. To improve the team's transitioning experience, more thorough documentation and details should be written for system components, hardware, and connections in the future.

III. Electrical System

A. Current Design

Last year, our electrical system consisted of a battery box, throttle box, motor controller, solar controller, telemetry box, and bilge unit. The battery box in Fig. 3 used a Victron BMV-712 monitor for voltage and current monitoring capabilities. The bilge unit housed an auxiliary battery to power the bilge pump. All other electrical system components have been discussed in their respective sections.



Figure 3: The battery systems use the Victron Energy BMV-712 monitor and 500A shunt resistor.

B. Analysis of Design Concepts

We have kept the same battery box system. The BMV-712 unit communicates with the telemetry server over USB; its data is integrated into the telemetry system. Since it's a drive-by-wire throttle, the original throttle box was replaced with a telemetry node, which takes a throttle input and sends it to the telemetry system. As much of the team focused this year on collecting data to evaluate subsystems and guide design decisions, many new electronic systems were added to interface with new peripherals to obtain this data. Several sensors were added, discussed below. Schematics for all telemetry devices can be found in *Appendix F: Electrical System Data*.

The solar charger node is used to determine the output current of the solar chargers to the batteries. This is used to evaluate how much energy the system is receiving from the sun and forward it to the server to budget energy for use in the endurance competition. There is a socket for the main microcontroller and two hall-effect-based, bi-directional 50A current, one for each of the solar chargers. These sensors were currently packaged into a solar charger to handle a maximum of 14 A each with a 20°C rise. This is so that the two sensors can independently handle all the current solar panels while managing the heat transfer appropriately. The solar node is used in the box with the solar chargers and set up to take input from the solar panels. Section VI: Solar Energy System contains more information on the solar energy system.

C. Design Testing and Evaluation

Each of these boards was constructed as a prototype using a breadboard. Once satisfied with the functionality, we designed and ordered a PCB. The PCBs were assembled, tested, and integrated into the boat systems. Future efforts will include expanding the telemetry sensors to

include more nodes. Because the system is modular, each PCB collects only a few data points. Adding new boards that collect more data is designed to be convenient under this system.

IV. Power Electronics System

A. Past Configuration

1) Sprint Design: The previous team bought the larger LEM-200 95 motor, shown in Fig. 5. This motor has a higher-rated torque output and handles the power requirements of our application better than the new motor. Since the Alltrax cannot be controlled directly via serial data, we needed to create a circuit that would convert the throttle control signal to one of the inputs of the Alltrax controller. We built a sensor node that converts the telemetry data point to a resistance value, which the Alltrax controller reads and converts to a throttle value. (*For more information, see Appendix G, Section D: Notes on Alltrax Throttle Control.*)

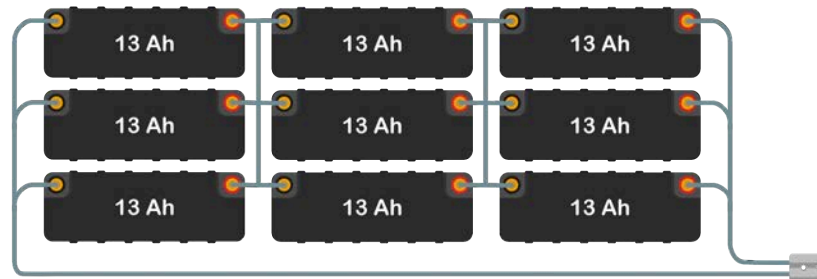

Figure 4: The battery layout utilized in the 2018 team's sprint mode, with three series-connected sets of 3 parallel batteries, for a total of 39 Ah at 36 V.



Figure 5: LEM-200 95 brushed motor used by our team in 2019. The motor is shown mounted on its adapter plate for the direct-drive system.

2) Endurance Design: The 2019 endurance battery pack consisted of three Genesis EP 42 Ah batteries in series for a single 42 Ah, 36 V battery set. They chose the Alien Power Systems 6374S motor, which is a 42 V, 2.8 kW rated motor, because its speed constant is similar to the propeller's rated speed. Fig. 7 Left reveals the size of the Alien motor.



Figure 6: The battery layout for the 2019 year's endurance mode consists of three 42 Ah batteries in series for a total of 42 Ah.



Figure 7: Left: The Alien Power Systems 6374S motor used by the 2019 team for Endurance mode. Right: The VESC 4 motor controller is used in Endurance with the motor.

They chose the VESC 4 motor controller to drive the BLDC. The VESC can be controlled through a USB serial connection (shown in Fig. 7 Right), and the telemetry server implements the VESC protocol, allowing it to communicate with the device. This allowed them to track data points without an intermediary microcontroller, as required with the Alltrax. To interface our Python telemetry program with the VESC, we used the PyVESC library^[3].

B. New Configuration

1) Battery Design: Our team previously had an electric setup for both Sprint and Endurance modes. However, we had to adapt and change since only one set of batteries is allowed in competition now. The endurance race is worth 150 more points than the sprint race, so we used the previous endurance setup as our baseline and began optimization from there.



Figure 8: The 2024 battery layout consists of three 45 Ah batteries in series, for a total of 45 Ah at 36V.

2) Analysis of Design Concepts: Since we are limited to one set of batteries this year, we optimized for endurance. We chose to buy the 12 V, 45 Ah UPS TLV12450F6 for their high capacity and also for their high rate of discharge. The batteries can discharge up to 450 A (for five seconds), making them adept for sprinting. We installed these batteries in our battery box in

the array shown in Fig. 8. Sprinting is equipped with water-resistant output plugs for both power and data and a dual fan system for cooling.

3) Sprint Motor Setup: We continued using the LEM-200 motor for sprints this year. Its high power and torque rating makes it ideal for high speeds and low distances. In previous years, we controlled the motor using the Alltrax motor control. Still, instead of preventing it with our telemetry system, we opted to control it with a physical throttle in the form of a 0-5k Curtis pot box.

4) Endurance Motor Setup: We used the Alien Power Systems 6374S motor again. It is easily controllable using our VESC controller, which allows us to control factors such as duty cycle, rpm, etc. It also allows us to track and graph motor temperature, current draw, power, and battery voltage information. We can provide input to the VESC via an RC controller or an Arduino input module.

5) Design Testing and Evaluation: We performed endurance configuration testing in various conditions, including no-load bench testing, testing on a rig, and testing on the water. We have not performed speed testing with the endurance configuration yet, but we plan to continue testing up to the competition. The sensor on the endurance motor was damaged during the handling, so we continued to record rpm using an Arduino and hall sensor to print out RPM onto an LCD.

C. Power Budget

As discussed in the *Overall Project Objectives* section of this report, one of our primary technical goals was to create a power budget that would be enforced during endurance to ensure that our boat could maintain a constant speed throughout the endurance heat without being required to stop.

Appendix L: Power Budget contains the formula and procedure for the power budget. Our calculations found that our team should aim to draw approximately 28 A, assuming an 80% solar efficiency. By designing for this specification and driving the boat not to exceed this value, our team will be able to successfully avoid exceeding this value by stopping the boat.

In future competitions, we plan to build the power budget ship a program running on the boat. This program will automatically adjust the maximum throttle based on the energy received from the solar panels and the state of the battery system. This automation will further help optimize our system for endurance.

V. Drivetrain and Steering

A. Drivetrain

1) Current Design: The previous team designed a direct drive and spent time identifying propellers that would match the motor characteristics they would use. Since the strategy would require a broader range of propellers, they planned to modify the Evinrude lower unit to accommodate larger propellers, up to 14”.

They designed a direct drive system that connects the motor through a jaw coupling to the outboard shaft. Modeled drive units are shown in Fig. 9 and Fig. 10. The direct drive unit was

designed to make switching between Endurance and Sprint motors easy. Each motor switching has its plate, which can easily be interchangeably bolted down to the upper unit. Each motor has its own upper jaw coupling, which always stays mounted to the m and meshes with the bottom unit. For detailed CAD drawings of the components, see *Appendix H, Section B: Drivetrain CAD Drawings*.

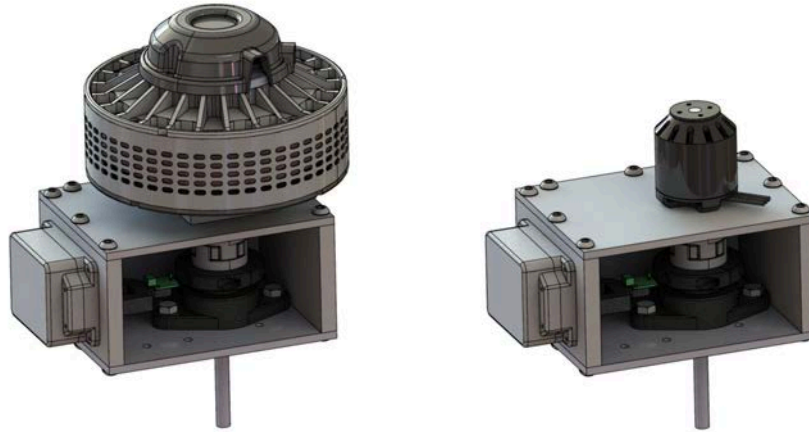

Figure 9: Left: The upper drive unit is shown with the sprint motor installed. Right: The upper drive unit is shown with the endurance motor installed. Note the bolts on the upper plates, which are unscrewed to change which motor is used in the assembly.

They modified the lower unit by removing the ventilation plate, allowing for larger propellers. For more information about this process, see *Appendix H, Section C: Lower Unit Modifications*.

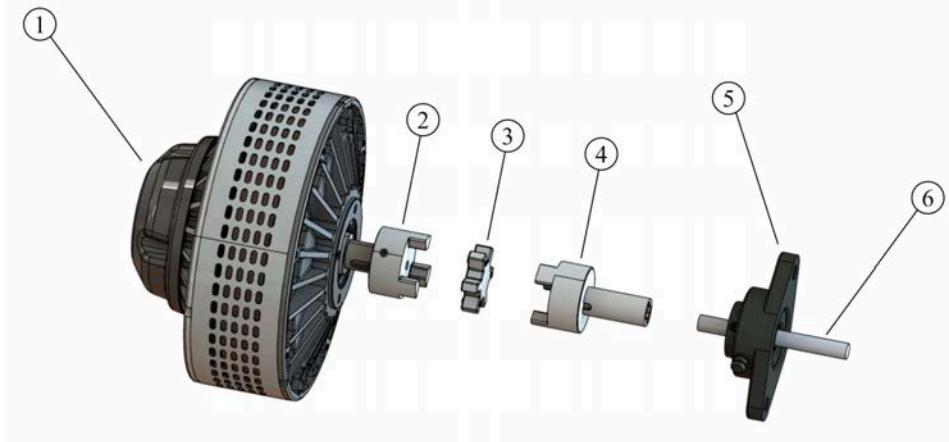

Figure 10: An exploded view of the main drivetrain components in the upper unit; left to right: ① Motor, ② Upper jaw coupling, ③ Rubber “spider”, ④ Lower jaw coupling and shaft adapter, ⑤ Bearing, ⑥ Outboard shaft

2) Analysis of Design Concepts:

The 2019 team encountered several issues with the drivetrain unit that we aimed to address in this year's iteration. The main problem stemmed from our initial assumption that the motor could deliver sufficient torque when geared up nearly 2:1. This gearing aimed to increase the propeller speed at this gearing. Still, it turned out that the motor could not produce enough

torque, causing the system to draw more current than our power electronics and batteries could handle. Additionally, due to this mismatch, the system was operating outside the motor's intended range, resulting in operator output.

To optimize motor performance, we realized there were better options than overloading the motor to lower RPM. Instead, we drove the motor at its maximum RPM while maintaining sufficient torque.

As a solution, we planned to implement a direct drive system and invest time in identifying propellers that align with the motor's characteristics. This approach would necessitate a broader selection of propellers. We intended to modify the Evinrude lower unit to accommodate larger propellers, up to 14 inches in diameter.

Our design involved a direct drive system that connects the motor to the outboard shaft via a jaw coupling. This setup was engineered to ease the transition between endurance and sprint motors. Each motor is mounted on its plate, allowing interchangeable bolting down to the upper. Additionally, each motor has its upper jaw coupling, which remains mounted to the motor and consistently with the bottom unit. Detailed CAD drawings of these components can be found in Appendix H, Section B: Drivetrain CAD Drawings.

3) Design Testing and Evaluation: After completing the fabrication of the drivetrain, the 2019 team performed several stages of testing. Early in the development, they performed bench testing, pictured in Fig. 11. Our team built a test stand that submerged the propeller in a tub of water, allowing us to approximate the load of a boat in the water. The motor was connected to a waterproof, portable battery box. The motor was connected to the VESC software to gather data regarding the motor. VESC software can control and report data. We wrote code to relate RPMs to the motor amperage. Once the drivetrain system was completed, we tested it on the water.



Figure 11: Inside the test room, a tub of water with the propeller is submerged. The motor stand has a force gauge meter strung around it to collect thrust.



Figure 12: 2019: The boat was in the water during a testing session in December, during which we tested the drivetrain's efficiency at low speeds.

This testing validated our decision to update to a direct drive; the new direct drive system eliminates the majority of vibration and noise the drivetrain had previously, indicating it has increased mechanical efficiency. Additionally, our telemetry system allowed us to compare the systems quantitatively. We had to compare the systems quantitatively. The current draw of approximately 300 A was on our old system. During the previous testing sessions, represented by Fig. 12, we reached a speed of 9 mph with a current draw of approximately 80 A. This is a significant increase in efficiency for our team. We have not yet tested the full speed of the boat, which requires a new propeller with a higher pitch.

B. Propellers

1) Current Design: Previously, our team used 8" propellers designed for our team, illustrated in Fig. 13. There were two Torqeedo propellers on the Evinrude outboard, one for sprint and one for endurance. These propellers were chosen because Torqeedo motors have a very similar shaft RPM to our system, with a maximum RPM of 1600 on most models. Additionally, the propellers use a shear-pin style, which matches our outboard.

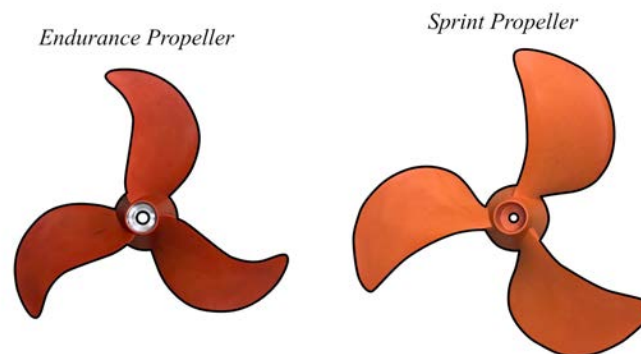

Figure 13: Left: The Torqeedo v8/p350 propeller is used for endurance competitions.

Right: The Torqeedo v30/p4000 propeller is used for sprint competition events.

Data about the performance characteristics can be found in *Appendix H, Section A: Torqeedo Propeller Datasheets*. The sprint propeller is rated for 30 knots, and the endurance propeller is rated for 8 knots. These match our target speed ranges in each of the events. The diameter of the largest propeller, 12.6", fits on our outboard with the modifications that have been made this year.

2) Analysis of Design Concepts: A propeller establishes the baseline efficiency standard. The existing propeller's efficiency needs to meet the Solar Splash vehicle's optimal performance requirements, with the challenge of the upcoming June 4th competition looming. Efficiency, as defined by the equation $\text{Efficiency} = J * K_t(x) / (2 * \pi * K_q(x))$, where K_t represents the thrust coefficient, and K_q denotes the torque coefficient, stands as a pivotal metric in our design endeavor. The toroidal sparked our interest. Fig. 14 exemplifies the design.



Figure 14: CAD Model of the Toroidal Propeller.

A comprehensive set of requirements guides our design and testing process, and the testing process integrates with Solar Splash's existing motor. Additionally, durability is essential; the propeller's connection to the motor must endure applied torque, validated through rigorous testing protocols. Fit is also crucial; the propeller must adhere to defined spatial constraints within its mount and testing rig. Efficiency optimization is a key focus, with performance maximized at the motor's most efficient RPM. Maximizing performance is expected to outperform the 1915-00 Torqeedo v8/p380 propeller in terms of efficiency. Safety considerations are prioritized, with testing procedures strictly following guidelines established by the mechanical engineering department, encompassing emergency shutdown protocols and safety feature implementation.

Furthermore, the system must facilitate comprehensive data collection, recording thrust and RPM data during testing. Versatility is emphasized, with the propeller optimized for a range of RPMs and capable of operating across various torque levels. Finally, meticulous instrument calibration ensures the accuracy and reliability of collected data throughout the testing process.

3) Design and Testing Evaluation: We conducted a series of tests and analyses to ensure the accuracy and reliability of our testing rig and propeller designs. More data can be found in *Appendix M: Propeller Data*. First, we tested the Solar Splash propeller's RPM vs. thrust twice to validate the testing rig's accuracy. Following this, we 3D scanned the Solar Splash propeller and created a digital file in NX Siemens, which we used to 3D print a replica for further testing. The data from testing the actual propeller was then compared to the 3D-printed replica to assess the performance of different materials. We designed, printed, and tested a toroidal propeller using NX Siemens, comparing its actual performance in RPM vs. thrust to simulation results. Furthermore, we compared the Solar Splash propeller to the toroidal propeller in terms of torque, RPM, and thrust to determine their efficiencies, as shown in Fig. 15.

After analyzing the data from the initial test comparing the toroidal propeller and the Solar Splash propeller, we focused on optimizing the toroidal propeller. In the optimization

process, we created 21 different parameters for the toroidal propeller and utilized a Taguchi array for simulation, details of which are discussed further in the design of experiment section. All results from the optimization process were printed and tested (3). To enhance the durability and performance of the toroidal propeller, we 3D printed an optimal design and later fabricated it out of aluminum. We then compared the aluminum toroidal propeller's RPM, torque, and thrust to its 3D-printed counterpart and the current propeller to evaluate the differences in efficiencies.

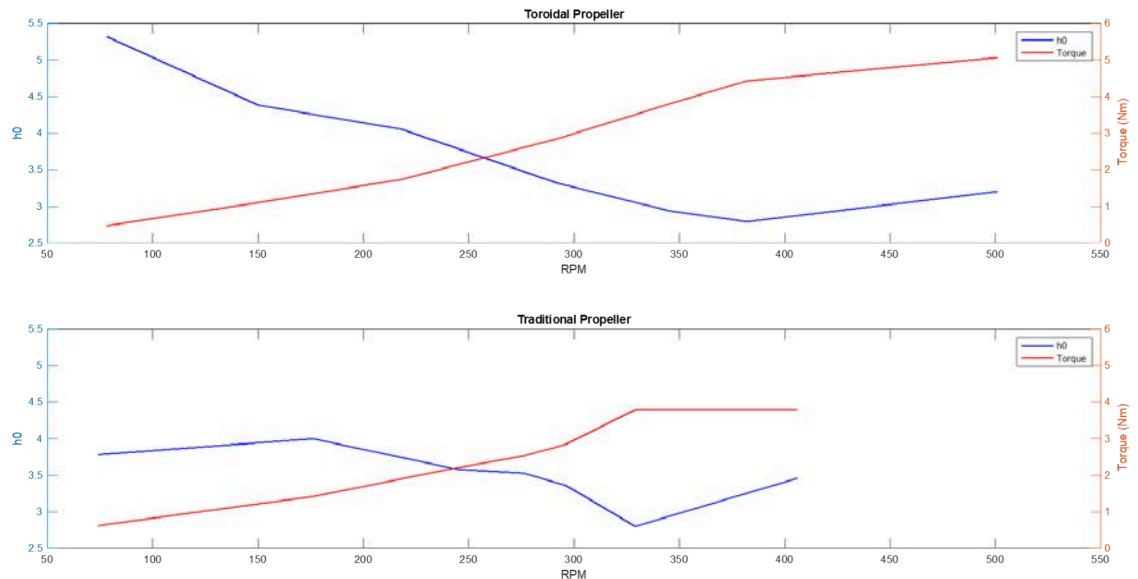

Figure 15: Efficiency toroidal compared to current, traditional propeller based on the RPM.

C. Steering System

1) Current Design: The Rochester team has been utilizing electrical steering systems for several years. This was motivated by the presence of the custom drivetrain/hull, which made it difficult to use a conventional drivetrain/hull as a cable or hydraulic kit. This steering system used a linear actuator and lever to steer the motor back and forth, as shown in Fig. 16t.

2) Analysis of Design Concepts: This electrical steering system was ineffective. The design of the lever meant that large off-axis forces resulted in high bearing stress on the bolts, causing them to shear during competition. Second, the steering system had no feedback through resistance on the wheel, so it was very hard to control. Additionally, the lever system had an extra degree of freedom, which made off-axis alignment possible, jamming the steering. The cable related to jamming is highlighted in Fig. 17.

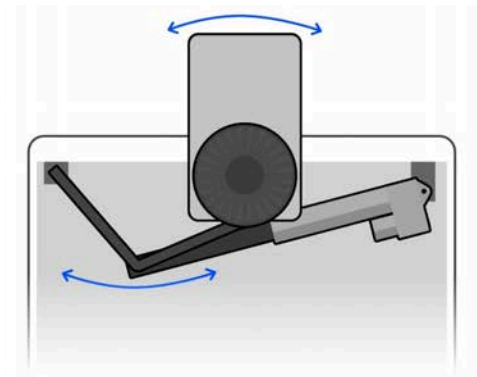

Figure 16: Linear Actuator Movement.

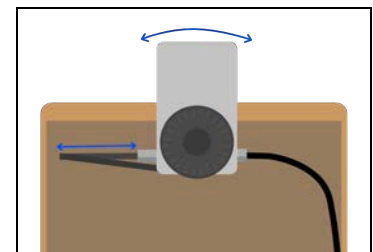

Figure 17: Steering Rotation.

3) Design Testing and Evaluation: After analyzing the options for the steering system, the team elected to return to steering system options. This matched up well with the decision to use an older hull because the hull had mounting holes for a Teleflex adapter used previously.

Because our outboard model did not have mounting holes for the Teleflex cable directly, we mounted the Teleflex rear unit to the boat's transom underneath the motor. This required the team to manufacture a rod connecting the steering cable's end to the outboard. This connects the steering cable's steel rod, with ball joints on either end to allow for rotation. The layout of the steering system is shown in the figure to the right. The Teleflex cable was attached to the side rail of the boat, and the steering unit was mounted on the dashboard. To minimize moments on the bolt, we used a shorter bolt and connected the steering as close to the height of the outboard mount as possible.

VI. Solar Energy System

A. Solar Panels

1) Previous Design: In our last competition, we used two SBM Solar, Inc. panels, which were rated for 516 W together, which was above the power requirement for that competition. Therefore, 175.61 square inches of the panels were taped over to meet requirements. The change of rule 7.3.2 to “entries are permitted to have 720 Watts under normal one sun conditions. A minimum of 360 Watts of solar power under one sun condition must be carried on the boat in all events. The onboard solar configuration must remain the same for all events” has led to us re-evaluating our solar system. During the years since our last competition, the team has experimented with solar tracking stands using linear actuators; however, this would not be permitted with panels that need to remain stationary. Thus, a stationary stand design was explored.

2) Current Analysis of Design Concepts: For this competition, we will be using two SBM Solar, Inc. panels rated at 280 W each in parallel, for a total of 560 W that falls below the 720 W threshold. See *Appendix I, Section B: Solar Panel Datasheets*. Both panels will remain on the boat, which also meets the requirement for 360W of solar to be carried on the boat during all events. The panels are equipped with an existing aluminum frame along the rear edge of the panels.

To optimize the sun contact with panels. We chose to have a stand with them lying parallel to the boat drawn in Fig. 18. The stand is made from wood for budget and simplicity purposes, and a hinge and latch design is used to allow for the panels to be raised to access electronics without needing to remove the panels entirely. A latch is used on the opposite end of each hinge to secure the panel down when the panels are not lifted. During events, to satisfy rule 7.3.2, the latch serves to keep the panels secure at a constant position for all events.

The stands themselves take a flattened ‘U’ shape that wraps around the aluminum frame on the back of each panel. With the inability to easily secure a nut and bolt perpendicular to the panel’s face through the existing aluminum frame, the ‘U’ design was used so a bolt could pass through the wooden stand (parallel to the panel face) and through the side of the aluminum frame

with a nut to secure it easily accessible on the inside edge of the existing aluminum frame. There are two of these ‘U’ shapes for each panel, for four total.

The stands are secured to the boat with either one or two hinges on one ‘U’ and a latch on the other ‘U’ for each panel. The hinges are secured to the boat with screws into supporting cross-sections, where wooden panels go across the width of the boat. The latches are screwed into the wooden ‘U,’ with the receiving fitting for the latch secured to the boat.

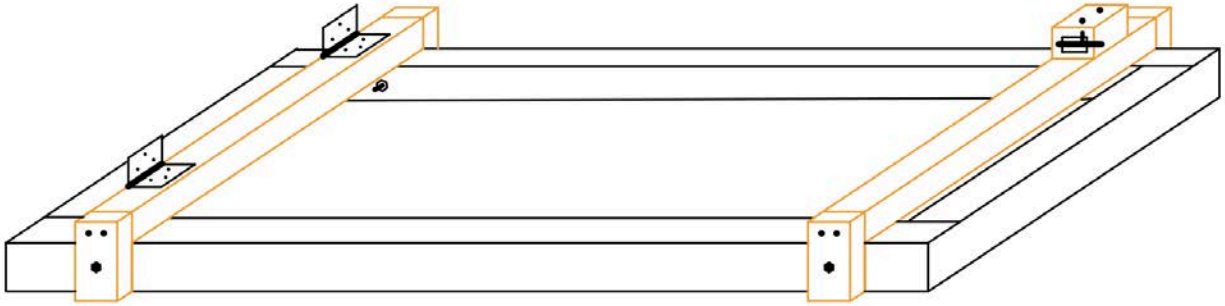

Figure 18: Drawing of solar stand attached to back of panel. Note the panel faces downward, the hinges on the left end, and the latch on the right end.



Figure 19: Photos of solar panels mounted on front of boat (left) and rear of boat (right).

3) Design Testing and Evaluation: At this time, the fabrication of the solar stands is complete, and we are working on attaching the panels to the stands, followed by attaching both the panels and stands to the boat. During boat testing, we plan to evaluate the usability of the new design. We will observe both panels' performance with sun contact, the security of the panels in place while the boat is moving on the water, and finally, if the hinge design successfully allows easy access to electronics beneath the panels on the boat.

B. Solar Chargers

1) Current Design: In our previous design, each solar panel was connected to a Genasun GV-Boost 8A 36V charger, with both charge controllers connected in parallel to the battery system through a shunt resistor for current monitoring purposes, as seen in Fig. 20 below.

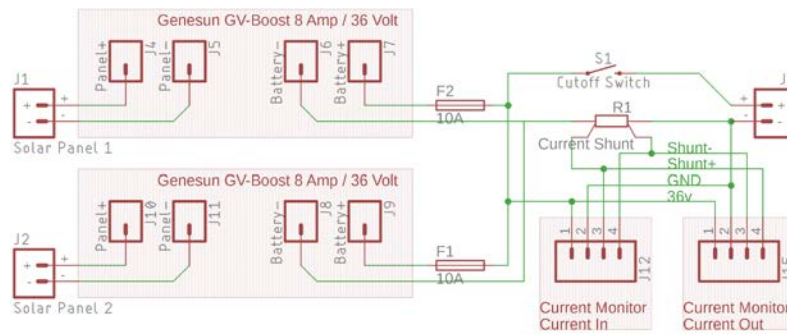

Figure 20: The schematic for the parallel-wired Genasun controllers used in our team's previous design.

These chargers were chosen for their voltage step-up capability, allowing the use of solar panels at a lower voltage than the batteries. Most MPPT solar chargers are step-down converters, meaning the solar panel voltage must be higher than the battery voltage. A boost converter is required in our system to convert the lower input voltage from the panels to a higher voltage for battery charging. (For an explanation of the background behind this, see Appendix I, Section C: Explanation of Step-Down vs. Boost MPPT Chargers.)

The entire system was contained in a waterproof enclosure with quick-disconnect connectors to the solar panels and battery. Fig. 21 is the box to ensure waterproofing.

Figure 21: The previously completed solar charger module, with solar charger input/battery output cables, current monitoring LCDs, and an on/off switch.



2) Analysis of Design Concepts: The solar chargers we chose are effective for our purposes, and we have no plans to replace them. We have designed improvements to the solar system's monitoring capability to complement our larger telemetry system efforts.

Although the previous solar charger system had current monitoring capability, the value was only displayed physically on an LCD, meaning it was impractical for the driver to read while in the boat. Additionally, the data was not saved for later review.

We designed a sensor board with two shunt resistors, measuring the output from each solar charger. The solar charging current is passed through a PCB, which reads it and sends it to the telemetry system. Using an online trace width calculator, we verified that the PCB traces could support the maximum charging current with acceptable power loss^[1].

Another concern with the previous solar system was the size of the enclosure. We purchased a smaller enclosure and used a 3d printed mounting system on the interior of the box to mount the solar chargers and telemetry board. Fig. 22 is the illustration of the new enclosure. To further improve the size of the components, we began using XT-60 and XT-90 connectors instead of the larger Anderson power connectors used previously.



Figure 22: Updated enclosure for Solar Energy System. ① Telemetry USB connection ② 36 V battery output ③ Solar panel inputs

3) Design Testing and Evaluation

To test our solar system, we repeatedly brought the panels out in a variety of sunlight conditions. During these tests, we connected a dummy load in the form of a motor running at full throttle, which drew approximately 10A (360w). While this testing was not qualitative, it allowed us to debug potential problems with the telemetry sensor data and verify that the charging system works as intended. Fig. 23 shows the testing setup. As we approach the competition, we plan to perform endurance testing on the water with the new system.



Figure 23: An example of our solar testing in the field: Both panels connected to the system at dusk and in partial shade. Our team plans to perform a number of these tests at different light intensities and weather conditions.

VII. Hull Design

A. Hull Design History

Appendix J, Section B: Hull Design History, provides a brief history of hull designs. Our team returned to a premade hull purchased at the club's inception. In Fig. 24, the 16-ft square-stern cargo canoe performed well at the 2010 competition. By using the preexisting hull, our team was able to narrow our focus on other subsystems, improving a single area of our boat's design at a time.



Figure 24: We reused the Great Canadian Ungava Bay 16 flat-stern canoe.

B. Analysis of Design Concepts

This year, we elected to continue using the square-stern canoe. After trying to build a hull ourselves and not reaching the deadline, we went under the philosophy that spending less time on hull design would allow our team to focus its limited efforts elsewhere. The previous boat was left outside, only covered by a tarp. The inside was rotten, but the epoxy preserved the hull to extend its lifetime. However, we had to reimagine substantially with the rule changes, the weathered down boat, and many large drivetrain changes. We had the following concerns:

- The rotten wood impacted the boat's strength. We needed to strip the boat down to the outermost hull, resand, epoxy, and internally support it with stringers.
- The previous benches and stringers were not in ideal locations; their positioning made it hard to fit the driver, electronics, and solar panels. Also, the center of mass was going to be impacted, so we modeled new locations for stringers to increase hull strength.

We used the 2019 prototype hull constructed in Solidworks and previously ran fluid simulations (CFD) on the hull model to better understand the hull. The 2019 team defined the boat's fluid dynamics and shared areas for improvement. Details of this tool and its usage in hull modeling can be found in *Appendix J, Section C: Hydrostatics Testing Program*.

Since refurbishing required heavy sanding and chipping away at the epoxy, we needed to test whether the boat had any holes. We put the boat on the water in the fall semester and tested its floatation. Fig. 25 shows the boat on the water. Testing was done in 3 feet of water with Safety Advisors. The boat was attached to the dock for the entire test. The boat floated and only had one hole for repair.



Figure 25: First time the hull went on the water.

To solve strength issues, we planned a hull reinforcement design and a set of modifications that would improve the hull's usability at competition. We took their advice and then modeled the hull in Fusion 360 ourselves. Once the hull was in Fusion 360, we were able to start determining the internal structure and placement of drivetrain components.



Figure 26: Left: Closeup of the transom, which had rotted out and needed replacement. Right: CAD model of the planned hull reinforcements, which would replace the benches.

C. Design Testing and Evaluation

We performed the hull modifications in the fall. We started by stripping the hull down to its fiberglass shell, removing stringers and gunwale, as shown in Fig. 26. Then, we sanded and painted to the best of our ability. Next, we fabricated and reinforced the parts for the frame. We purchased Okoume- Marine plywood (sizes: 2 or 3 mm thick 2'x 4' boards) from Chesapeake Light Craft. Before attaching the reinforcements to the hull with fiberglass, we encapsulated all wooden parts with epoxy. After assembling the reinforcements, we painted the interior with marine top coat paint. The buoyancy boxes were filled with closed-cell floatation foam. We built a deck using marine plywood; this provides a waterproof surface covering the floatation foam.

After completing the structural components, we added a system of straps and tie-downs to mount all the electronics in the boat's hull. Fig. 27 represents current progress. The hull is

almost completed but still ready for testing before the competition. For a more detailed timeline of the hull modification process, see *Appendix J, Section A: Hull Modification Process*.



Figure 27: Pictures of the modified hull, which is ready for water testing.

VIII. Project Management

A. Team Members and Leadership Roles

The University of Rochester Solar Splash team is a club team consisting solely of undergraduate students. The club is led by an executive board, an elected panel of leaders in charge of leading the project's overall direction. The executive board also holds weekly meetings with advisors and faculty, maintains communication among the team, and ensures the team stays on schedule. For a detailed description of the roles in the executive board, see *Appendix K: Project Management Data*.

B. Project Planning and Schedule

Project planning was divided into several categories by subsystem of the boat: Electrical System, Telemetry System, Solar Panel team, and Mechanical team. Our team set goals for each design area and tracked our progress toward each goal. Our planning mirrored the modular nature of our system; each subsystem had a separate task board maintained, and the group responsible for that system kept the list updated. We used an Excel spreadsheet to organize projects in the form of a Gantt Chart, Fig. 28.

Project Planner

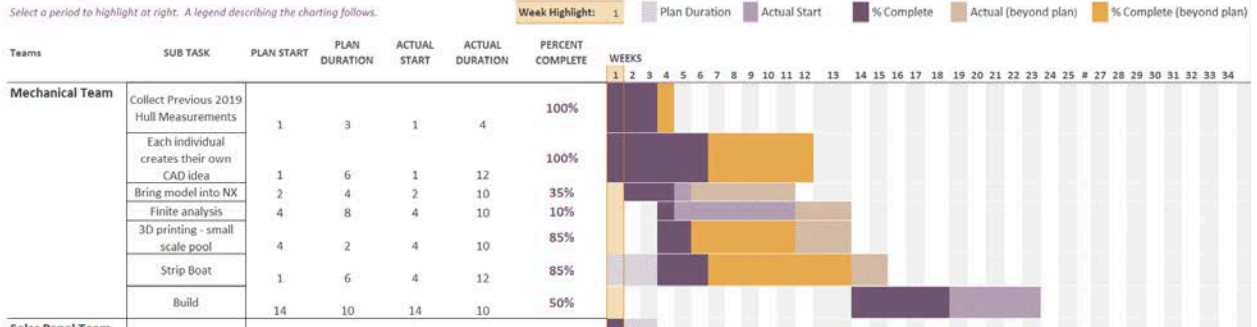

Figure 28: Gantt Chart of projects per team.

Our planning was relatively informal in previous years, and we did not set week-to-week deadlines. We previously used Trello or Asana as a management system, which provided a TODO list. However, this year, we focused on active communication through weekly meetings. The subteam would take specific meeting minutes and present them during weekly check-ins. This encouraged more interaction between subteams to facilitate easier construction on the boat.

We did not receive any sponsorships this year, but we did continue using previously given sponsorship equipment, like motors from Lynch Motors.

We also extensively used GroupMe, a group communication software, to organize meetings. GitHub was the primary form of communication for the Telemetry team.

C. Financing and Fundraising

The Rochester Solar Splash Team is funded annually by the Hajim Engineering School and the Rochester Student Association. As an engineering club, our group is responsible for submitting a yearly budget to both institutions to continue receiving funding. The Hajim Engineering School contributed \$1,742, and the Student Association contributed \$3,042 for a total budget of \$4,784.

This budget covers our engineering expenses and travel expenses, including hotel and gas, for the yearly competition trip. The team kept track of its spending using spreadsheets that tabulated all the semester costs, shown in *Appendix K, Section B: Budgeting Documentation*.

D. Strategy for Team Continuity and Sustainability

Because we are an undergraduate club, our team relies on the recruitment of new members to sustain itself. The primary method for recruiting new members is through presence at a variety of school events and activity fairs.

Our team has achieved varied success with recruitment at these fairs in the past. Last year, we set a goal of becoming more active in the campus community. This year, we fulfilled that goal, participating in a number of events both on and off campus. We participated in the ASME pumpkin launch, which is a competition of pumpkin launchers among engineering groups from our school. We placed 3rd at this competition. We also helped plan and participate in social events for the engineering school. This included an Engineering Ball for the past 2 years and

Family Science Day, where our organization shared a lesson and activity about buoyancy to grade school students from Rochester. We also partnered with our UR Makers club to have a workshop about soldering.

E. Discussion and Self-Evaluation

Overall, this has been a very productive year for our team. We achieved all the goals we set at the beginning of the year and are ending the year with a set of modular systems that can be expanded.

An ongoing concern is the future of the club's leadership. Membership is not strictly defined by the hours or meetings attended. An individual can help a lot on a task for a specified stretch. Because of this new style of attendance, our membership has significantly increased since students like the flexibility and can help with specific interests when the time presents itself. However, commitment requires strict consistency to be an EBoard member. Many people enjoy the engineering and building aspects of the club. The president is responsible for administration and communication with the school. Many team members like being flexible, helping, and designing, but there is no interest in filling the Business Manager role. In the future, it is believed that adding a secretary can take the stress off potential candidates for sending out club emails, organizing events/volunteering, and communicating with advisors.

IX. Conclusions and Recommendations

A. Strengths

- Equipped with new batteries.
- Demonstrated proficiency in both competition basics and technical skills.
- Successfully participated in the competition.
- Enhanced the club's reputation on campus.

B. Weaknesses

- Failed to engage in projects aimed at enhancing performance metrics, such as efficiency or effectiveness.
- Limited to a single battery set configuration, restricting adaptability and potential optimization opportunities for different scenarios or requirements.
- Limited Telemetry data, even though sensors once worked and utilized.

C. Lessons Learned.

- Future teams should start working on documentation of the systems as they build them; this helps pass along the knowledge so the system can be used later and makes writing the technical report easier.
- With a functioning boat, future teams should work on optimizing. This year, the main goal was to just get to the competition. We were more direct in our engineering practices and strictly followed previous years' systems. Sacrificing optimization, we just wanted to present a functioning boat. We would have loved to spend more time designing subcomponents and diving deeper into research to make our boat even better.

D. Achievement of Objectives

We achieved our goals for this semester. We reignited the club and got a boat to competition, and all of the goals identified in our Overall Project Objectives were met for this

year. Given our progress this semester, we are optimistic that we will succeed in this year's competition and in future years.

E. Future Objectives

In future semesters, we aim to work on quantitatively testing all aspects of our system, taking advantage of the modularity and sensing capability. We also aim to construct a more efficient boat.





References

- [1] “PCB Trace Width Calculator”. *Advanced Circuits*. 2018
<https://www.4pcb.com/trace-width-calculator.html>
- [2] “VESC – Open Source ESC” *Benjamin Vedder*. 2016
<http://vedder.se/2015/01/vesc-open-source-esc/>
- [3] “PyVESC Documentation” *Liam Bindle*. 2017
<https://pyvesc.readthedocs.io/en/latest/>
- [4] “Ungava Bay 16” *Playak.com*. 2010
<http://playak.com/buyers-guide/boats-boards/great-canadian-ungava-bay-16>
- [5] “Metalico Rochester” *Metalico Rochester*. 2017
<http://www.metalicorochester.com/>
- [6] “IV Curve” *PVEducation.org*. 2019
<https://www.pveducation.org/pvcdrom/solar-cell-operation/iv-curve>

Appendix A: Battery Documentation

A. Material Safety Data Sheets

Below is the MSDS for the UPS batteries used in both Endurance and Sprint.

		SAFETY DATA SHEET		Form #: 853027 Revised: AC Supersedes: AB (12-16-16) ECO #: 1001828	
I. PRODUCT IDENTIFICATION					
Chemical Trade Name (as used on label): Cyclon®, Odyssey, Genesis®, SBS, XE®, Armsafe Plus®, MILPC, Nexsys, or Large TPPL.				Chemical Family/Classification: Sealed Lead Battery	
Synonyms: Sealed Lead Acid Battery, VRLA Battery				Telephone: For information and emergencies, contact EnerSys Energy Products Environmental, Health & Safety Dept. at 660-429-2165	
Manufacturer's Name/Address: EnerSys Energy Products Inc. 617 N. Ridgeview Drive Warrensburg, MO 64093-9301				24-Hour Emergency Response Contact: CHEMTREC DOMESTIC: 800-424-9300 CHEMTREC INTL: 703-527-3877	
II GHS HAZARDS IDENTIFICATION					
HEALTH		ENVIRONMENTAL		PHYSICAL	
Acute Toxicity (Oral/Dermal/Inhalation) Category 4 Skin Corrosion/Irritation Category 1A Eye Damage Category 1 Reproductive Category 1A Carcinogenicity (lead compounds) Category 1B Carcinogenicity (acid mist) Category 1A Specific Target Organ Toxicity (repeated exposure) Category 2		Aquatic Chronic 1 Aquatic Acute 1		Explosive Chemical, Division 1.3	
GHS LABEL:					
HEALTH		ENVIRONMENTAL		PHYSICAL	
					
Hazard Statements DANGER! Causes severe skin burns and serious eye damage. May damage fertility or the unborn child if ingested or inhaled. May cause cancer if ingested or inhaled. Causes damage to central nervous system, blood and kidneys through prolonged or repeated exposure. May form explosive air/gas mixture during charging. Extremely flammable gas (hydrogen). Explosive, fire, blast, or projection hazard. May cause harm to breast-fed children Harmful if swallowed, inhaled, or contact with skin Causes skin irritation, serious eye damage.			Precautionary Statements Wash thoroughly after handling. Do not eat, drink or smoke when using this product. Wear protective gloves/protective clothing, eye protection/face protection. Avoid breathing dust/fume/gas/mist/vapors/spray. Use only outdoors or in a well-ventilated area. Contact with internal components may cause irritation or severe burns. Avoid contact with internal acid. Irritating to eyes, respiratory system, and skin. Obtain special instructions before use. Do not handle until all safety precautions have been read and understood Avoid contact during pregnancy/while nursing Keep away from heat/sparks/open flames/hot surfaces. No smoking		
III. COMPOSITION/INFORMATION ON INGREDIENTS					
Components		CAS Number		Approximate % by Weight	
Inorganic Lead Compound:					
Lead		7439-92-1		45 - 60	
Lead Dioxide		1309-60-0		15 - 25	
Tin		7440-31-5		0.1 - 0.2	
Sulfuric Acid Electrolyte (Sulfuric Acid/Water)		7664-93-9		15 - 20	
Case Material:				5 - 10	
Polypropylene		9003-07-0			
Polystyrene		9003-53-6			
Styrene Acrylonitrile		9003-54-7			
Acrylonitrile Butadiene Styrene		9003-56-9			
Styrene Butadiene		9003-55-8			
Polyvinylchloride		9002-86-2			
Polycarbonate, Hard Rubber, Polyethylene		9002-88-4			
Polyphenylene Oxide		25134-01-4			
Polycarbonate/Polyester Alloy		--			
Other:					



SAFETY DATA SHEET

Form #: 853027
 Revised: AC
 Supersedes: AB (12-16-16)
 ECO #: 1001828

Absorbent Glass Mat	--	1 - 2				
Inorganic lead and sulfuric acid electrolyte are the primary components of every battery manufactured by EnerSys Energy Products. There are no mercury or cadmium containing products present in batteries manufactured by EnerSys Energy Products.						
IV. FIRST AID MEASURES						
Inhalation:						
Sulfuric Acid: Remove to fresh air immediately. If breathing is difficult, give oxygen. Consult a physician						
Lead: Remove from exposure, gargle, wash nose and lips; consult physician.						
Ingestion:						
Sulfuric Acid: Give large quantities of water; do not induce vomiting or aspiration into the lungs may occur and can cause permanent injury or death; consult a physician						
Lead: Consult physician immediately.						
Skin:						
Sulfuric Acid: Flush with large amounts of water for at least 15 minutes; remove contaminated clothing completely, including shoes. If symptoms persist, seek medical attention. Wash contaminated clothing before reuse. Discard contaminated shoes						
Lead: Wash immediately with soap and water.						
Eyes:						
Sulfuric Acid and Lead: Flush immediately with large amounts of water for at least 15 minutes while lifting lids						
Seek immediate medical attention if eyes have been exposed directly to acid.						
V. FIRE FIGHTING MEASURES						
Flash Point: N/A		Flammable Limits: LEL = 4.1% (Hydrogen Gas)		UEL = 74.2% (Hydrogen Gas)		
Extinguishing Media: Carbon dioxide; foam; dry chemical. Avoid breathing vapors. Use appropriate media for surrounding fire.						
Special Fire Fighting Procedures:						
If batteries are on charge, shut off power. Use positive pressure, self-contained breathing apparatus. Water applied to electrolyte generates heat and causes it to spatter. Wear acid-resistant clothing, gloves, face and eye protection.						
Note that strings of series connected batteries may still pose risk of electric shock even when charging equipment is shut down.						
Unusual Fire and Explosion Hazards:						
Highly flammable hydrogen gas is generated during charging and operation of batteries. To avoid risk of fire or explosion, keep sparks or other sources of ignition away from batteries. Do not allow metallic materials to simultaneously contact negative and positive terminals of cells and batteries. Follow manufacturer's instructions for installation and service.						
VI. ACCIDENTAL RELEASE MEASURES						
Spill or Leak Procedures:						
Stop flow of material, contain/absorb small spills with dry sand, earth, and vermiculite. Do not use combustible materials. If possible, carefully neutralize spilled electrolyte with soda ash, sodium bicarbonate, lime, etc. Wear acid-resistant clothing, boots, gloves, and face shield. Do not allow discharge of unneutralized acid to sewer. Acid must be managed in accordance with local, state, and federal requirements. Consult state environmental agency and/or federal EPA.						
VII. HANDLING AND STORAGE						
Handling:						
Unless involved in recycling operations, do not breach the casing or empty the contents of the battery.						
There may be increasing risk of electric shock from strings of connected batteries						
Keep containers tightly closed when not in use. If battery case is broken, avoid contact with internal components.						
Keep vent caps on and cover terminals to prevent short circuits. Place cardboard between layers of stacked automotive batteries to avoid damage and short circuits.						
Keep away from combustible materials, organic chemicals, reducing substances, metals, strong oxidizers and water. Use banding or stretch wrap to secure items for shipping.						
Storage:						
Store batteries in cool, dry, well-ventilated areas with impervious surfaces and adequate containment in the event of spills. Batteries should also be stored under roof for protection against adverse weather conditions. Separate from incompatible materials. Store and handle only in areas with adequate water supply and spill control. Avoid damage to containers. Keep away from fire, sparks and heat. Keep away from metallic objects which could bridge the terminals on a battery and create a dangerous short-circuit						
Charging:						
There is a possible risk of electric shock from charging equipment and from strings of series connected batteries, whether or not being charged. Shut-off power to chargers whenever not in use and before detachment of any circuit connections. Batteries being charged will generate and release flammable hydrogen gas. Charging space should be ventilated. Keep battery vent caps in position. Prohibit smoking and avoid creation of flames and sparks nearby. Wear face and eye protection when near batteries being charged.						
VIII. EXPOSURE CONTROLS/PERSONAL PROTECTION						
Exposure Limits (mg/m3) Note: N.E.= Not Established						
INGREDIENTS (Chemical/Common Names)	OSHA PEL	ACGIH	US NIOSH	Quebec PEV	Ontario OEL	EU OEL
Lead and Lead Compounds (inorganic)	0.05	0.05	0.05	0.05	0.05	0.15 (b)
Tin	2	2	2	2	2	N.E
Sulfuric Acid Electrolyte	1	0.2	1	1	0.2	0.05 (c)
Polypropylene	N.E	N.E	N.E	N.E	N.E	N.E
Polystyrene	N.E	N.E	N.E	N.E	N.E	N.E
Styrene Acrylonitrile	N.E	N.E	N.E	N.E	N.E	N.E
Acrylonitrile Butadiene						
Styrene	N.E	N.E	N.E	N.E	N.E	N.E



SAFETY DATA SHEET

Form #: 853027

Revised: AC

Supersedes: AB (12-16-16)

ECO #: 1001828

Styrene Butadiene	N.E	N.E	N.E	N.E	N.E	N.E
Polyvinylchloride	N.E	N.E	N.E	N.E	I	N.E
Polycarbonate, Hard Rubber, Polyethylene	N.E	N.E	N.E	N.E	N.E	N.E
Polyphenylene Oxide	N.E	N.E	N.E	N.E	N.E	N.E
Polycarbonate/Polyester Alloy Rubber, Polyethylene	N.E	N.E	N.E	N.E	N.E	N.E
Absorbent Glass Mat	N.E	N.E	N.E	N.E	N.E	N.E

NOTES:

(b) As inhalable aerosol

(c) Thoracic fraction

Engineering Controls (Ventilation):

Store and handle in well-ventilated area. If mechanical ventilation is used, components must be acid-resistant.

Handle batteries cautiously to avoid spills. Make certain vent caps are on securely. Avoid contact with internal components. Wear protective clothing, eye and face protection when filling, charging or handling batteries. Do not allow metallic materials to simultaneously contact both the positive and negative terminals of the batteries. Charge the batteries in areas with adequate ventilation. General dilution ventilation is acceptable.

Respiratory Protection (NIOSH/MSHA approved):

None required under normal conditions. When concentrations of sulfuric acid mist are known to exceed the PEL, use NIOSH or MSHA-approved respiratory protection.

Skin Protection:

If battery case is damaged, use rubber or plastic acid-resistant gloves with elbow-length gauntlet, acid-resistant apron, clothing and boots

Eye Protection:

If battery case is damaged, use chemical goggles or face shield.

Other Protection:

Under severe exposure emergency conditions, wear acid-resistant clothing and boots.

IX. PHYSICAL AND CHEMICAL PROPERTIES**Properties Listed Below are for Electrolyte:**

Boiling Point:	203 - 240° F	Specific Gravity (H₂O = 1):	1.215 to 1.350
Melting Point:	N/A	Vapor Pressure (mm Hg):	10
Solubility in Water:	100%	Vapor Density (AIR = 1):	Greater than 1
Evaporation Rate: (Butyl Acetate = 1)	Less than 1	% Volatile by Weight:	N/A
pH:	~1 to 2	Flash Point:	Below room temperature (as hydrogen gas)
LEL (Lower Explosive Limit)	4.1% (Hydrogen)	UEL (Upper Explosive Limit)	74.2% (Hydrogen)
Appearance and Odor:	Manufactured article; no apparent odor. Electrolyte is a clear liquid with a sharp, penetrating, pungent odor.		

X. STABILITY AND REACTIVITYStability: Stable X Unstable **This product is stable under normal conditions at ambient temperature****Conditions To Avoid:** Prolonged overcharge; sources of ignition**Incompatibility: (Materials to avoid)****Sulfuric Acid:** Contact with combustibles and organic materials may cause fire and explosion. Also reacts violently with strong reducing agents, metals, sulfur trioxide gas, strong oxidizers and water. Contact with metals may produce toxic sulfur dioxide fumes and may release flammable hydrogen gas.**Lead Compounds:** Avoid contact with strong acids, bases, halides, halogenates, potassium nitrate, permanganate, peroxides, nascent hydrogen and reducing agents.**Hazardous Decomposition Products:****Sulfuric Acid:** Sulfur trioxide, carbon monoxide, sulfuric acid mist, sulfur dioxide, and hydrogen sulfide.**Lead Compounds:** High temperatures likely to produce toxic metal fume, vapor, or dust; contact with strong acid or base or presence of nascent hydrogen may generate highly toxic arsine gas.**Hazardous Polymerization:**

Will not occur

XI. TOXICOLOGICAL INFORMATION**Routes of Entry:****Sulfuric Acid:** Harmful by all routes of entry.**Lead Compounds:** Hazardous exposure can occur only when product is heated, oxidized or otherwise processed or damaged to create dust, vapor or fume. The presence of nascent hydrogen may generate highly toxic arsine gas.**Inhalation:****Sulfuric Acid:** Breathing of sulfuric acid vapors or mists may cause severe respiratory irritation.**Lead Compounds:** Inhalation of lead dust or fumes may cause irritation of upper respiratory tract and lungs.**Ingestion:****Sulfuric Acid:** May cause severe irritation of mouth, throat, esophagus and stomach.**Lead Compounds:** Acute ingestion may cause abdominal pain, nausea, vomiting, diarrhea and severe cramping. This may lead rapidly to systemic toxicity and must be treated by a physician.**Skin Contact:****Sulfuric Acid:** Severe irritation, burns and ulceration.



SAFETY DATA SHEET

Form #: 853027

Revised: AC

Supersedes: AB (12-16-16)

ECO #: 1001828

Lead Compounds: Not absorbed through the skin.

Eye Contact:

Sulfuric Acid: Severe irritation, burns, cornea damage, and blindness.

Lead Compounds: May cause eye irritation.

Effects of Overexposure - Acute:

Sulfuric Acid: Severe skin irritation, damage to cornea, upper respiratory irritation.

Lead Compounds: Symptoms of toxicity include headache, fatigue, abdominal pain, loss of appetite, muscle aches and weakness, sleep disturbances and irritability.

Effects of Overexposure - Chronic:

Sulfuric Acid: Possible erosion of tooth enamel, inflammation of nose, throat and bronchial tubes.

Lead Compounds: Anemia; neuropathy, particularly of the motor nerves, with wrist drop; kidney damage; reproductive changes in males and females. Repeated exposure to lead and lead compounds in the workplace may result in nervous system toxicity. Some toxicologists report abnormal conduction velocities in persons with blood lead levels of 50mcg/100 ml or higher. Heavy lead exposure may result in central nervous system damage, encephalopathy and damage to the blood-forming (hematopoietic) tissues.

Carcinogenicity:

Sulfuric Acid: The International Agency for Research on Cancer (IARC) has classified "strong inorganic acid mist containing sulfuric acid" as a Group 1 carcinogen, a substance that is carcinogenic to humans. This classification does not apply to liquid forms of sulfuric acid or sulfuric acid solutions contained within a battery. Inorganic acid mist (sulfuric acid mist) is not generated under normal use of this product. Misuse of the product, such as overcharging, may result in the generation of sulfuric acid mist.

Lead Compounds: Lead is listed as a Group 2A carcinogen, likely in animals at extreme doses. Per the guidance found in OSHA 29 CFR 1910.1200 Appendix F, this is approximately equivalent to GHS Category 1B. Proof of carcinogenicity in humans is lacking at present.

Medical Conditions Generally Aggravated by Exposure:

Overexposure to sulfuric acid mist may cause lung damage and aggravate pulmonary conditions. Contact of sulfuric acid with skin may aggravate diseases such as eczema and contact dermatitis. Lead and its compounds can aggravate some forms of kidney, liver and neurologic diseases.

Acute Toxicity:

Inhalation LD50:

Electrolyte: LC50 rat: 375 mg/m³; LC50: guinea pig: 510 mg/m³

Elemental Lead: Acute Toxicity Point Estimate = 4500 ppmV (based on lead bullion)

Oral LD50:

Electrolyte: rat: 2140 mg/kg

Elemental Lead: Acute Toxicity Estimate (ATE) = 500 mg/kg body weight (based on lead bullion)

Additional Health Data:

All heavy metals, including the hazardous ingredients in this product, are taken into the body primarily by inhalation and ingestion. Most inhalation problems can be avoided by adequate precautions such as ventilation and respiratory protection covered in Section 8. Follow good personal hygiene to avoid inhalation and ingestion: wash hands, face, neck and arms thoroughly before eating, smoking or leaving the worksite. Keep contaminated clothing out of non-contaminated areas, or wear cover clothing when in such areas. Restrict the use and presence of food, tobacco and cosmetics to non-contaminated areas. Work clothes and work equipment used in contaminated areas must remain in designated areas and never taken home or laundered with personal non-contaminated clothing. This product is intended for industrial use only and should be isolated from children and their environment.

The 19th Amendment to EC Directive 67/548/EEC classified lead compounds, but not lead in metal form, as possibly toxic to reproduction.

Risk phrase 61: May cause harm to the unborn child, applies to lead compounds, especially soluble forms.

XII. ECOLOGICAL INFORMATION**Environmental Fate:**

Lead is very persistent in soil and sediments. No data on environmental degradation. Mobility of metallic lead between ecological compartments is slow.

Bioaccumulation of lead occurs in aquatic and terrestrial animals and plants but little bioaccumulation occurs through the food chain.

Most studies include lead compounds and not elemental lead.

Environmental Toxicity: Aquatic Toxicity:

Sulfuric acid: 24-hr LC50, freshwater fish (Brachydanio rerio): 82 mg/L

96 hr- LOEC, freshwater fish (Cyprinus carpio): 22 mg/L

Lead: 48 hr LC50 (modeled for aquatic invertebrates): <1 mg/L, based on lead bullion

Additional Information:

· No known effects on stratospheric ozone depletion.

· Volatile organic compounds: 0% (by Volume)

· Water Endangering Class (WGC): NA

XIII. DISPOSAL CONSIDERATIONS (UNITED STATES)

Spent batteries: Send to secondary lead smelter for recycling. Spent lead-acid batteries are not regulated as hazardous waste when the requirements of 40 CFR Section 266.80 are met. This should be managed in accordance with approved local, state and federal requirements. Consult state environmental agency and/or federal EPA.

Electrolyte:

Place neutralized slurry into sealed containers and handle as applicable with state and federal regulations. Large water-diluted spills, after neutralization and testing, should be managed in accordance with approved local, state and federal requirements. Consult state environmental agency and/or federal EPA.

Following local, State/Provincial, and Federal/National regulations applicable to end-of-life characteristics will be the responsibility of the end-user.

XIV. TRANSPORT INFORMATION



SAFETY DATA SHEET

Form #: 853027

Revised: AC

Supersedes: AB (12-16-16)

ECO #: 1001828

U.S. DOT:

Excepted from the hazardous materials regulations (HMR) because the batteries meet the requirements of 49 CFR 173.159(f) and 49 CFR 173.159a of the U.S. Department of Transportation's HMR. Battery and outer package must be marked "NONSPILLABLE" or "NONSPILLABLE BATTERY". Battery terminals must be protected against short circuits.

IATA Dangerous Goods Regulations DGR:

Excepted from the dangerous goods regulations because the batteries meet the requirements of Packing Instruction 872 and Special Provisions A67 of the International Air Transportation Association (IATA) Dangerous goods Regulations and International Civil Aviation Organization (ICAO) Technical Instructions. Battery Terminals must be protected against short circuits.

The words "NOT RESTRICTED", SPECIAL PROVISION A67" must be provided when the air waybill is issued.

IMDG:

Excepted from the dangerous goods regulations for transport by sea because the batteries meet the requirements of Special Provision 238 of the International Maritime Dangerous Goods (IMDG CODE). Battery terminals must be protected against short circuits.

Requirements for Safe Shipping and Handling of Cyclon Cells:

Warning – Electrical Fire Hazard – Protect against shorting. Terminals can short and cause a fire if not insulated during shipping. Cyclon product must be labeled "NONSPILLABLE" during shipping. Follow all federal shipping regulations. See section IX of this sheet and CFR 49 Parts 171 through 180, available online at www.gpoaccess.gov.

Requirements for Shipping Cyclon Product as Single Cells:

Protective caps or other durable inert material must be used to insulate each terminal of each cell unless cells are shipping in the original packaging from EnerSys, in full box quantities. Protective caps are available for all cell sizes by contacting EnerSys Customer Service at 1-800-964-2837.

Requirements for Shipping Cyclon Product Assembled Into Multicell Batteries:

Assembled batteries must have short circuit protection during shipping. Exposed terminals, connectors, or lead wires must be insulated with a durable inert material to prevent exposure during shipping.

XV. REGULATORY INFORMATION**UNITED STATES:****EPA SARA Title III:****Section 302 EPCRA Extremely Hazardous Substances (EHS):**

Sulfuric acid is a listed "Extremely Hazardous Substance" under EPCRA, with a Threshold Planning Quantity (TPQ) of 1,000 lbs. EPCRA Section 302 notification is required if 1000 lbs or more of sulfuric acid is present at one site (40 CFR 370.10). For more information consult 40 CFR Part 355. The quantity of sulfuric acid will vary by battery type. Contact your EnerSys representative for additional information

Section 304 CERCLA Hazardous Substances:

Reportable Quantity (RQ) for spilled 100% sulfuric acid under CERCLA (Superfund) and EPCRA (Emergency Planning and Community Right to Know Act) is 1,000 lbs. State and local reportable quantities for spilled sulfuric acid may vary.

Section 311/312 Hazard Categorization:

EPCRA Section 312 Tier Two reporting is required for non-automotive batteries if sulfuric acid is present in quantities of 500 lbs or more and/or if lead is present in quantities of 10,000 lbs or more. For more information consult 40 CFR 370.10 and 40 CFR 370.40

Section 313 EPCRA Toxic Substances:

40 CFR section 372.38 (b) states: If a toxic chemical is present in an article at a covered facility, a person is not required to consider the quantity of the toxic chemical present in such article when determining whether an applicable threshold has been met under § 372.25, § 372.27, or § 372.28 or determining the amount of release to be reported under § 372.30. This exemption applies whether the person received the article from another person or the person produced the article. However, this exemption applies only to the quantity of the toxic chemical present in the article.

Supplier Notification:

This product contains toxic chemicals, which may be reportable under EPCRA Section 313 Toxic Chemical Release Inventory (Form R) requirements. If you are a manufacturing facility under SIC codes 20 through 39, the following information is provided to enable you to complete the required reports:

Toxic Chemical	CAS Number	Approximate % by Wt.
Lead	7439-92-1	45 - 60
Sulfuric Acid Electrolyte (Sulfuric Acid/Water)	7664-93-9	15 - 20
Tin	7440-31-5	0.1 - 0.2

See 40 CFR Part 370 for more details.

If you distribute this product to other manufacturers in SIC Codes 20 through 39, this information must be provided with the first shipment of each calendar year.

The Section 313 supplier notification requirement does not apply to batteries, which are "consumer products".

TSCA:

TSCA Section 8b – Inventory Status: All chemicals comprising this product are either exempt or listed on the TSCA Inventory.

TSCA Section 12b (40 CFR Part 707.60(b)) No notice of export will be required for articles, except PCB articles, unless the Agency so requires in the context of individual section 5, 6, or 7 actions.

TSCA Section 13 (40 CFR Part 707.20): No import certification required (EPA 305-B-99-001, June 1999, Introduction to the Chemical Import Requirements of the Toxic Substances Control Act, Section IV.A)

RCRA:

Page 5



SAFETY DATA SHEET

Form #: 853027

Revised: AC

Supersedes: AB (12-16-16)

ECO #: 1001828

Spent Lead Acid Batteries are subject to streamlined handling requirements when managed in compliance with 40 CFR section 266.80 or 40 CFR part 273.
Waste sulfuric acid is a characteristic hazardous waste; EPA hazardous waste number D002 (corrosivity) and D008 (lead).

CAA:

EnerSys supports preventative actions concerning ozone depletion in the atmosphere due to emissions of CFC's and other ozone depleting chemicals (ODC's), defined by the USEPA as Class I substances. Pursuant to Section 611 of the Clean Air Act Amendments (CAAA) of 1990, finalized on January 19, 1993, EnerSys established a policy to eliminate the use of Class I ODC's prior to the May 15, 1993 deadline.

STATE REGULATIONS (US):**Proposition 65:**

Warning: Battery posts, terminals and related accessories contain lead and lead compounds, chemicals known to the State of California to cause cancer and reproductive harm. Batteries also contain other chemicals known to the State of California to cause cancer. Wash hands after handling.

INTERNATIONAL REGULATIONS:

Distribution into Quebec to follow Canadian Controlled Product Regulations (CPR) 24(1) and 24(2).

Distribution into the EU to follow applicable Directives to the Use, Import/Export of the product as-sold.

XVI. OTHER INFORMATION

Revised AC (04-25-17)

NFPA Hazard Rating for Sulfuric Acid:

Flammability (Red) = 0

Reactivity (Yellow) = 2

Health (Blue) = 3

Sulfuric acid is water-reactive if concentrated.

DISCLAIMER

This Safety Data Sheet is created by the manufacturer to comply with the requirements of 29 CFR 1910.1200. To the extent allowed by law, the manufacturer hereby expressly disclaims any liability to any third party, including users of this product, including, but not limited to, consequential or other damages, arising out of the use of, or reliance on, this Safety Data Sheet.

B. Battery Datasheets

Features of the TLV12450F11 - 12V 45Ah Sealed Lead Acid Battery with F11 - Insert Terminals

- Absorbent Glass Mat (AGM) technology for efficient gas recombination of up to 99% and freedom from electrolyte maintenance or water adding
- Not restricted for air transport-complies with IATA/ICAO Special Provision A67
- UL-recognized component
- Can be mounted in any orientation
- Computer designed lead, calcium tin alloy grid for high power density
- Long service life in float or cyclic applications
- Maintenance-free operation
- Low self discharge

Applications

- UPS Standby Power Applications
- Data Centers
- Emergency 911 Centers
- Hospitals & Medical Applications
- Military Power Equipment
- Emergency Lighting
- Fire Detection and Alarm Devices

Product Specifications

Dimensions

Terminal Type: F11
Length (mm/inch): 198/7.79
Width (mm/inch): 166/6.53
Height (mm/inch): 171/6.73
Total Height (mm/inch): 171/6.73
Approx. Weight (kg/lbs): 13.5/29.7

Performance Characteristics

Cells Per Unit: 6

Voltage Per Unit: 12

Capacity: 45Ah@10hr-rate to 1.80V per cell @25°C

Maximum Discharge Current:
450A (5 sec)

Internal Resistance:
Approx. 8mΩ

Operating Temperature Range

Discharge: -20°C ~ 60°C

Charge: 0°C ~ 50°C

Storage: -20°C ~ 60°C

Nominal Operating Temperature Range:
25°C±5°C

Float Charging Voltage:
13.6 to 13.8 VDC/unit Average at 25°C

Recommended Maximum Charging Current: 13.5A

Equalization and Cycle Service:
14.6 to 14.8 VDC/unit Average at 25°C

Self Discharge:

Batteries can be stored for more than 6 months at 25°C.
Self-discharge ratio less than 3% per month at 25°C.
Please charge batteries before using.

Container Material: A.B.S. UL94-HB, UL94-V0 Optional.

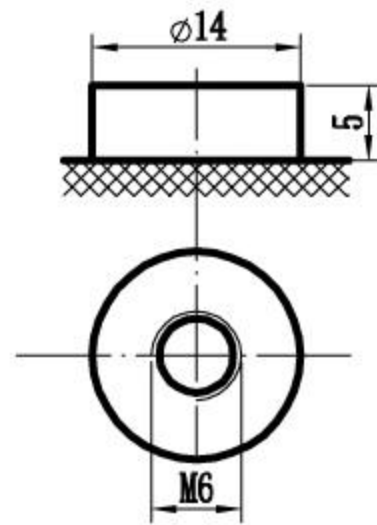
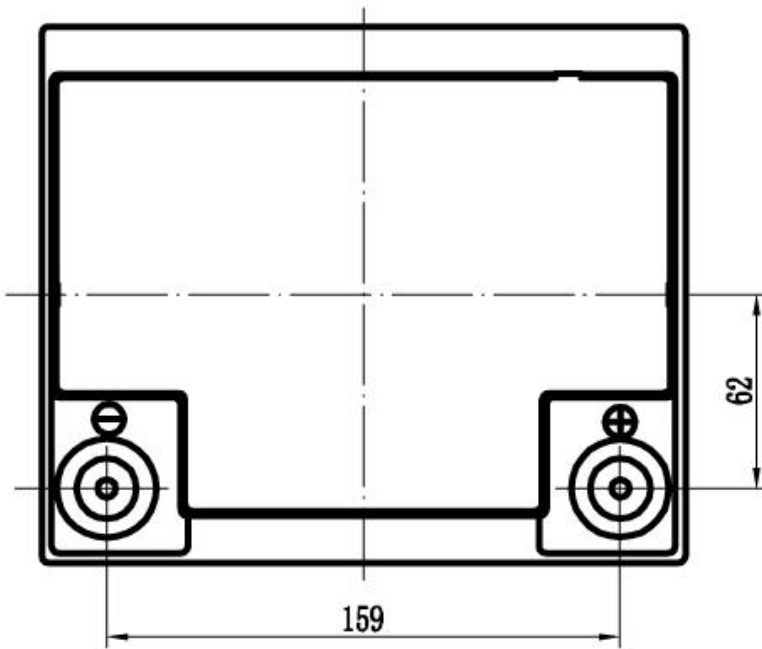
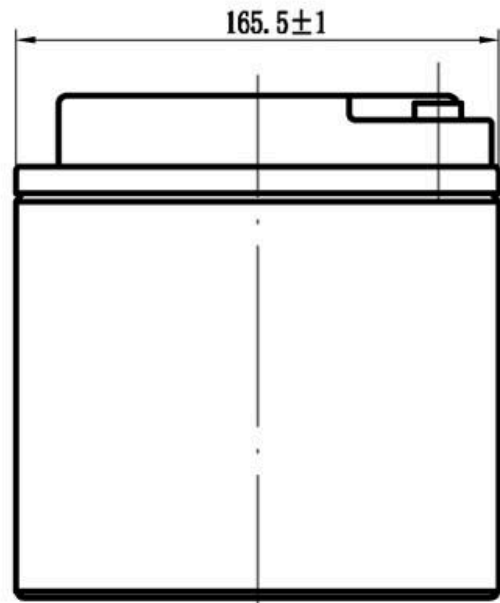
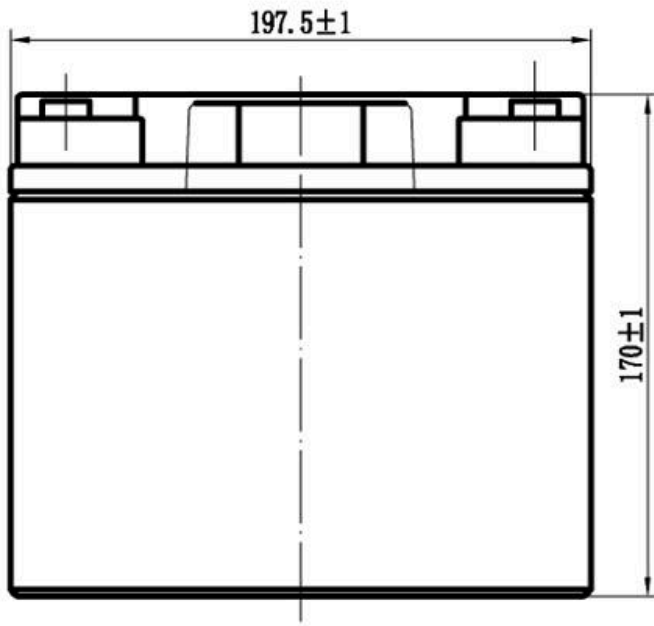

Terminal F11

Constant Current Discharge Characteristics

F.V/Time	5MIN	10MIN	15MIN	30MIN	1HR	2HR	3HR	4HR	5HR	8HR	10HR	20HR
9.60V	157.6	116.0	86.54	45.21	28.09	17.34	11.78	9.50	7.89	5.20	4.68	2.48
10.0V	153.0	110.4	84.76	44.63	27.71	16.99	11.57	9.37	7.82	5.18	4.64	2.43
10.2V	148.5	106.5	83.43	43.95	27.45	16.81	11.46	9.27	7.77	5.13	4.59	2.39
10.5V	133.3	98.26	79.44	42.74	27.11	16.59	11.36	9.14	7.70	5.08	4.55	2.34
10.8V	120.3	89.60	73.23	41.33	26.74	16.46	11.23	8.82	7.66	5.06	4.50	2.32
11.1V	102.7	80.08	65.68	39.76	26.10	15.79	11.01	8.70	7.61	5.02	4.45	2.22

Constant Power Discharge Characteristics

F.V/Time	5MIN	10MIN	15MIN	30MIN	1HR	2HR	3HR	4HR	5HR	8HR	10HR	20HR
9.60V	1662	1235	943.4	517.5	325.5	203.2	138.7	113.7	94.50	62.22	56.15	29.86
10.0V	1630	1198	928.3	512.2	322.5	200.7	136.7	112.1	93.65	61.98	55.71	29.34
10.2V	1611	1166	917.8	507.7	320.6	199.3	136.1	111.1	93.09	61.51	55.22	28.80
10.5V	1467	1086	875.5	497.4	318.6	196.8	135.0	109.6	92.34	60.99	54.67	28.26
10.8V	1336	1001	809.2	485.6	314.5	195.3	133.5	105.9	91.92	60.72	54.13	27.98
11.1V	1173	904.9	728.4	472.3	309.8	188.0	131.2	104.4	91.58	60.30	53.54	26.98

(Note) The above characteristics data are average values obtained within three charge/discharge cycles not the minimum values.

Battery Construction

Component	Positive plate	Negative plate	Container	Cover	Safety valve	Terminal	Separator	Electrolyte
Raw material	Lead dioxide	Lead	ABS	ABS	Rubber	Copper	Fiberglass	Sulfuric acid

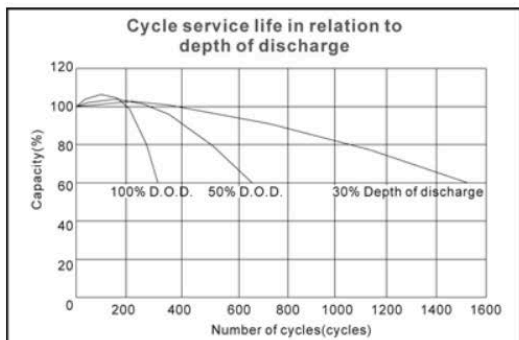
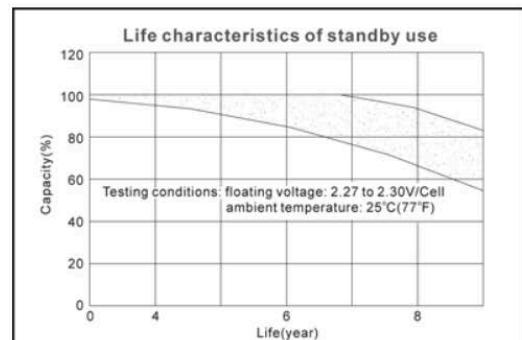
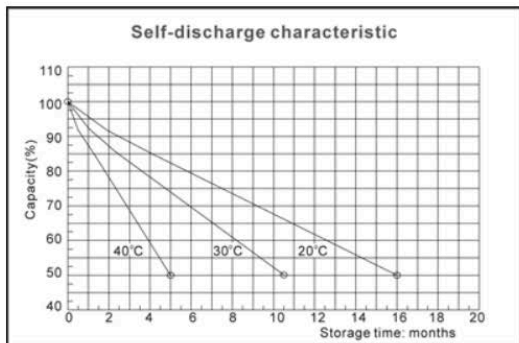
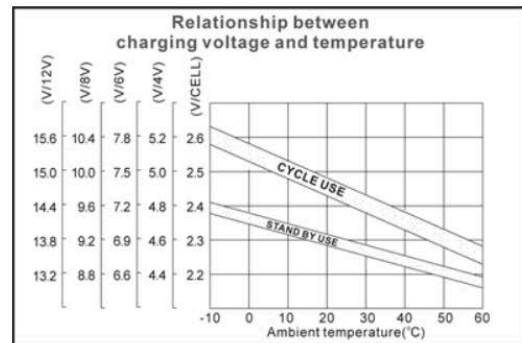
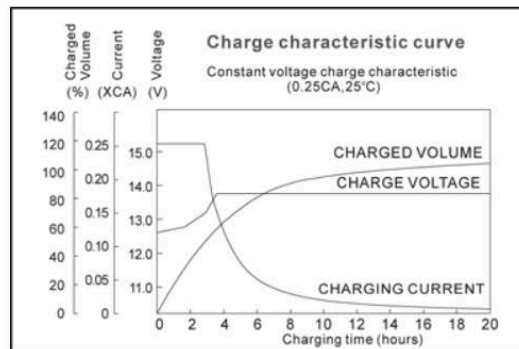
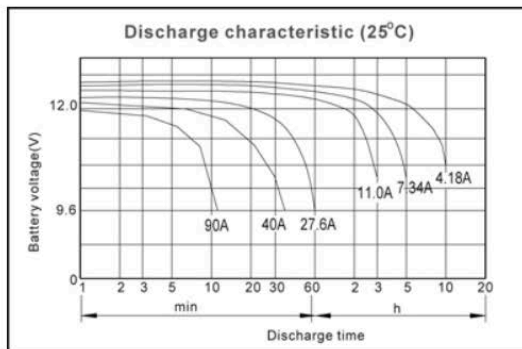

Appendix B: Flotation Calculations

Solar Splash Rule 7.13.4 Buoyancy of Craft: *Sufficient flotation must be provided on board so that the craft cannot sink, even when filled with water. A 20% safety factor must be included in the calculations. Verification calculations must be included in the Technical Report.*

As required by the above rule, our flotation calculations are shown below. Note: To simplify our calculations, we chose to disregard the volume of all objects on the boat except the boat hull itself. Assuming that all objects are dead weight with zero volume, which means they provide no buoyancy force, these calculations have an additional margin of safety.

<i>All Events Configuration</i>	
<i>Component</i>	<i>Weight (lbf)</i>
Boat Hull	-197.6
Solar Controller	2.8
Motor Controller	18.6
Telemetry Server	2.4
Telemetry Nodes	10.0
Bilge System	5.0
Solar Panels	41.2
Solar Panel Mounts	10.0
Cables	10.0
Steering System	10.0
Dashboard	5.0
Drivetrain	23.3
Motor Assembly	3.4
Battery Box	35.6
Battery Set	100.0
Total Force	-474.9
+20% Safety Factor	-569.88
Hull Buoyancy Force	584.87
Net Buoyancy Force	14.99 lbf

In both event mode, the net buoyancy force is 14.99 lbf as the solar arrangement will not be changed for each competition, meaning that the boat would float even if completely filled with water.

1) Hull Volume Calculation:

Ungava Bay 16 Specifications^[4]

Weight: 120 lbs

Center Line Depth: 16"

Center Line Length: 16'

Beam: 48"

To approximate the hull's displacement, we built a CAD model based on measurements of our hull and the modifications we performed to the hull this year. The hull model is a shell with a thickness of 0.2" (The fiberglass thickness on our boat), and the general hull shape was constructed from the Ungava Bay 16 specifications, as well as our measurements of the hull. For simplicity, we chose not to model the seat, dashboard, or other internal components in our buoyancy calculations.

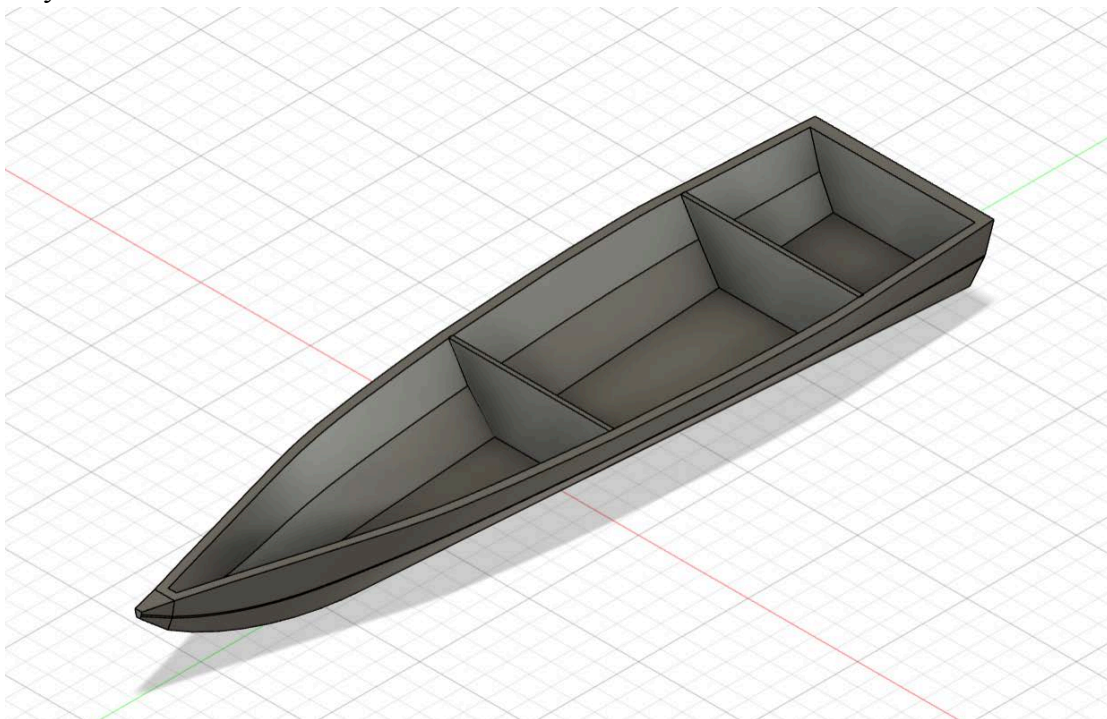

The hull with our stringers was modeled this year in Fusion 360.

Physical Properties for Ungava Bay 16 Model:

Weight = 198 lbs

Volume = 9.37295 ft³

Density of Water = 62.4 lbf/ft³

Displacement Force of Boat = Density of Water × Volume of Boat

Displacement Force of Boat = 62.4 lbf/ft³ × 9.37295 ft³ = 584.87 lbf

Appendix C: Proof of Insurance

Insurance Rule 2.10 Insurance - Each participating team is required to provide proof of general liability insurance from their educational institution or written proof that, as a state institution, they are self-insured. Proof of insurance must be supplied with the Technical Report. Failure to do so will result in a 10-point penalty applied to the Technical Report score.

Our proof of insurance, as required by the above rule, is shown below:

CERTIFICATE OF LIABILITY INSURANCE		DATE (MM/DD/YYYY) 04/25/2024				
<p>THIS CERTIFICATE IS ISSUED AS A MATTER OF INFORMATION ONLY AND CONFERS NO RIGHTS UPON THE CERTIFICATE HOLDER. THIS CERTIFICATE DOES NOT AFFIRMATIVELY OR NEGATIVELY AMEND, EXTEND OR ALTER THE COVERAGE AFFORDED BY THE POLICIES BELOW. THIS CERTIFICATE OF INSURANCE DOES NOT CONSTITUTE A CONTRACT BETWEEN THE ISSUING INSURER(S), AUTHORIZED REPRESENTATIVE OR PRODUCER, AND THE CERTIFICATE HOLDER.</p> <p>IMPORTANT: If the certificate holder is an ADDITIONAL INSURED, the policy(ies) must have ADDITIONAL INSURED provisions or be endorsed. If SUBROGATION IS WAIVED, subject to the terms and conditions of the policy, certain policies may require an endorsement. A statement on this certificate does not confer rights to the certificate holder in lieu of such endorsement(s).</p>						
PRODUCER MARSH USA, LLC. 507 PLUM STREET, SUITE 110 SYRACUSE, NY 13204 Attn: UniversityofRochester.certrequest@Marsh.com	CONTACT NAME: PHONE (A/C, No, Ext): FAX (A/C, No): E-MAIL ADDRESS:					
CN101472435-ALL-GAWXP-23-24		INSURER(S) AFFORDING COVERAGE NAIC # INSURER A : United Educators Ins Risk Ret. Grp. 10020 INSURER B : N/A N/A INSURER C : Travelers Property Casualty Company Of America 25674 INSURER D : N/A N/A INSURER E : INSURER F :				
INSURED UNIVERSITY OF ROCHESTER ATTN: KRISTIN MCCANN OFFICE OF COUNSEL P. O. BOX 278979 ROCHESTER, NY 14627-8979						
COVERAGES CERTIFICATE NUMBER: NYC-010278362-20 REVISION NUMBER: 6						
<p>THIS IS TO CERTIFY THAT THE POLICIES OF INSURANCE LISTED BELOW HAVE BEEN ISSUED TO THE INSURED NAMED ABOVE FOR THE POLICY PERIOD INDICATED. NOTWITHSTANDING ANY REQUIREMENT, TERM OR CONDITION OF ANY CONTRACT OR OTHER DOCUMENT WITH RESPECT TO WHICH THIS CERTIFICATE MAY BE ISSUED OR MAY PERTAIN, THE INSURANCE AFFORDED BY THE POLICIES DESCRIBED HEREIN IS SUBJECT TO ALL THE TERMS, EXCLUSIONS AND CONDITIONS OF SUCH POLICIES. LIMITS SHOWN MAY HAVE BEEN REDUCED BY PAID CLAIMS.</p>						
INSR LTR	TYPE OF INSURANCE	ADDL SUBR INSD WVD	POLICY NUMBER	POLICY EFF (MM/DD/YYYY)	POLICY EXP (MM/DD/YYYY)	LIMITS
A	<input checked="" type="checkbox"/> COMMERCIAL GENERAL LIABILITY <input type="checkbox"/> CLAIMS-MADE <input checked="" type="checkbox"/> OCCUR <input checked="" type="checkbox"/> Retention: \$500,000 occurrence <input checked="" type="checkbox"/> Liquor Liability - Included GEN'L AGGREGATE LIMIT APPLIES PER: <input checked="" type="checkbox"/> POLICY <input type="checkbox"/> PRO-JECT <input type="checkbox"/> LOC OTHER:		H07-25D	07/01/2023	07/01/2024	EACH OCCURRENCE \$ 500,000 DAMAGE TO RENTED PREMISES (Ea occurrence) \$ INCLUDED MED EXP (Any one person) \$ EXCLUDED PERSONAL & ADV INJURY \$ INCLUDED GENERAL AGGREGATE \$ 2,000,000 PRODUCTS - COMP/OP AGG \$ INCLUDED \$
	AUTOMOBILE LIABILITY <input type="checkbox"/> ANY AUTO <input type="checkbox"/> OWNED AUTOS ONLY <input type="checkbox"/> SCHEDULED AUTOS NON-OWNED AUTOS ONLY <input type="checkbox"/> HIRED AUTOS ONLY					COMBINED SINGLE LIMIT (Ea accident) \$ BODILY INJURY (Per person) \$ BODILY INJURY (Per accident) \$ PROPERTY DAMAGE (Per accident) \$ \$
A	<input type="checkbox"/> UMBRELLA LIAB <input checked="" type="checkbox"/> OCCUR <input checked="" type="checkbox"/> EXCESS LIAB <input type="checkbox"/> CLAIMS-MADE DED RETENTION \$		H07-25D	07/01/2023	07/01/2024	EACH OCCURRENCE \$ 2,000,000 AGGREGATE \$ 2,000,000 \$
C	WORKERS COMPENSATION AND EMPLOYERS' LIABILITY ANY PROPRIETOR/PARTNER/EXECUTIVE OFFICER/MEMBER EXCLUDED? (Mandatory in NH) If yes, describe under DESCRIPTION OF OPERATIONS below	Y/N <input checked="" type="checkbox"/> N <input type="checkbox"/> N/A	UB-8W767418-23-14-G NON NEW YORK	07/01/2023	07/01/2024	<input checked="" type="checkbox"/> PER STATUTE <input type="checkbox"/> OTH-ER E.L. EACH ACCIDENT \$ 1,000,000 E.L. DISEASE - EA EMPLOYEE \$ 1,000,000 E.L. DISEASE - POLICY LIMIT \$ 1,000,000
DESCRIPTION OF OPERATIONS / LOCATIONS / VEHICLES (ACORD 101, Additional Remarks Schedule, may be attached if more space is required) Evidence of Coverage.						
CERTIFICATE HOLDER				CANCELLATION		
American Association of Mechanical Engineers 309 Newridge Rd. Lexington, SC 29072				SHOULD ANY OF THE ABOVE DESCRIBED POLICIES BE CANCELLED BEFORE THE EXPIRATION DATE THEREOF, NOTICE WILL BE DELIVERED IN ACCORDANCE WITH THE POLICY PROVISIONS. AUTHORIZED REPRESENTATIVE <div style="text-align: right;"><i>Marsh USA LLC</i></div>		

Appendix D: Team Roster

A. Undergraduate Roster

Bolded names indicate Executive Board members, discussed previously in Project Management.

Name	Degree Program, Class Year	Team Role
Calista Courtney	Chemical Engineering (2024)	President
Alejandro Porras Diaz	Mechanical Engineering (2025)	Head Engineer
Will Knoff	Electrical Engineering (2025)	Electrical Project Manager
Riley Prewett	Chemical Engineering (2024)	Solar Project Manager
Leo Critchfield	Mechanical Engineering (2025)	Mechanical Project Manager
Tom Whiteley	Mechanical Engineering (2025)	Mechanical Project Manager
Sam Scheinbach	Mechanical Engineering (2028)	Mechanical Project Manager
Krish Jain	Computer Science (2025)	Telemetry Project Manager
Courtney Palmeri	Chemical Engineering (2026)	Member, Solar Team
Taryn Langtry	Geomechanics (2026)	Member, Solar Team
Rebeca Zapiach	Mechanical Engineering (2024)	Member, Mechanical Team
Jeremy Hur	Electrical Engineering (2027)	Member, Electric Team
Leon Zong	Computer Science (2025)	Member, Telemetry Team
Kevin Luo	Business (2026)	Member, Mechanical Team
Justin Zhu	Electrical Engineering (2027)	Member, Electric Team

B. Advisor Roster

Name	Advisor Role
Vincent Kindfueller	Faculty Advisor
Kyle DeManincor	Primary Advisor
Chris Muir	Mechanical Engineering Dept. Advisor
Jim Alkins	Additional Advisor

Appendix E: Telemetry Data

A. Description of Telemetry Protocol

Each telemetry node is a custom PCB based on ATmega32u4 microcontrollers connected to various peripherals used to collect data. These nodes are connected to the server using USB.

Once every second, the server scans its USB ports for new devices. If one is connected, it uses the device's attributes to choose which communication protocol to use. The server communicates with several types of devices. Most of the devices use a protocol designed by our team (the “Telemetry Protocol”). Still, the server can also communicate with other devices with proprietary protocols such as our current sensor.

When a node is powered on and plugged into the server, it continuously streams a byte (0x69) requesting to connect and identify as a URSS Telemetry Node device. The server then responds with a confirmation byte, and the node will respond with an enumerated `DEVICE_ID` byte to tell the server how to manage data from it and what data to send back to it. The server then responds with another confirmation byte, confirming that the device ID is valid and that the node is considered “connected” and ready to stream data. At any point during this handshake, if the server or node waits for more than 100ms without receiving the expected data, the connection times out, and the node will attempt to connect again.

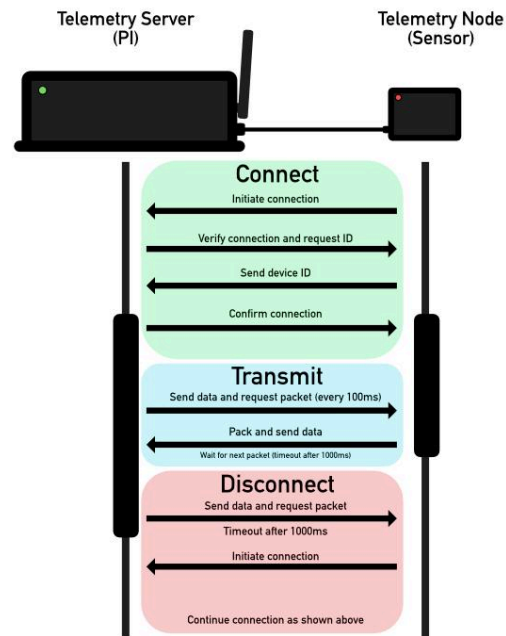

While a node is connected, it will wait for a request packet sent from the server at regular intervals. These request or “heartbeat” packets are sent at 4hz and can also contain data sent back to the nodes from the server. For example, the throttle data from the throttle board gets packed into binary data on the server and sent back to the motor controller board, which forwards that signal to the motor controller. When the node receives this request, it will unpack the transmitted data, pack the current data it has collected from its peripherals, and send it back to the server. Suppose at any point during this process, the node does not receive a heartbeat from the server or the server does not receive the data it expects within a second. In that case, the devices will return to the disconnected state and repeat the handshake to reconnect. This automatic

reconnection makes the protocol extremely robust, allowing users to disconnect and reconnect sensors freely without worrying about synchronizing the communication protocol as the server and node will automatically handle reconnecting.

The data the node sends to the server is broken into 16-byte packets. While most sensors only send one pack of data per request, some have too much data to compress into one packet. These packets follow a standard format consisting of a header byte shared between all packets (0xF0), 13 bytes of sensor data packed according to the device ID, a packet number byte identifying how to unpack the data for multipacket nodes, and an 8-bit checksum to ensure that none of the data was corrupted during transmission. Request packets are structured in a similar format.

Telemetry Packet Format

0	1	2	3	4	5	6	7	8	9	10	11	12	13	14	15
Header	Data Bytes (13)													Packet Number	Checksum

Node Implementation

While the new data transmission protocol implemented by the team is highly robust and capable of efficiently transmitting large quantities of data at high speeds, it is relatively complex. Implementing hexadecimal, bitmasks, bit shifting, and serial communication on the node sensors requires an understanding of hexadecimal, bit shifting, and serial communication. This can be a problem for new members of the club who are just beginning to learn embedded programming but still want to help improve the boat. To resolve this issue, the team has implemented the telemetry protocol in C++ for Arduino and packaged it as an expandable library that allows developers to easily leverage the protocol's capabilities with only a few lines of code. The source code for the telemetry nodes can be found [here](#) on GitHub.

A parent **TelemetryNode** object defines the handshake protocol and framework for receiving heartbeat packets and transmitting data. It has a virtual function interface for pack and unpack functions to implement on the child classes for each node. This makes it so that all developers need to do to define new nodes is to inherit from the parent object, add data fields for the values to send, and implement a pack and unpack function telling the node how to send and receive data. After the node has been defined, only a few lines of code are required to write an Arduino sketch for the node.

Example implementation of a device node and usage in an Arduino Sketch

```

class AlltraxNode : public TelemetryNode {
private:
    const uint8_t PACKET_START = 0xF0;
    void pack(void *p);
    void unpack();
public:
    uint16_t throt;
    uint16_t diodeTemp;
    uint16_t inVoltage;
    uint16_t outCurrent;
    uint16_t inCurrent;
    uint8_t dutyCycle;
    uint8_t errorCode;
    AlltraxNode(Serial_ *serialPort)
        : TelemetryNode(DEVICE_ALLTRAX, serialPort){};
};

void AlltraxNode::pack(void *p){
    Packet* packets = (Packet*)(p);
    packets[0].startByte=0xF0;
    uint16_t* p16 = (uint16_t*) (packets[0].data);
    p16[0] = diodeTemp;
    p16[1] = inVoltage;
    p16[2] = outCurrent;
    p16[3] = inCurrent;
    uint8_t *p8 = (uint8_t*)(&p16[4]);
    p8[0] = dutyCycle;
    p8[1] = errorCode;
    p8[2] = 0x00;
    p8[3] = 0x00;
    p8[4] = 0x00;
    packets[0].packetNum= 0x00;
    packets[0].checksum = 0x00;
    packets[0].checksum = _checksum(&packets[0]);
}

void AlltraxNode::unpack(){
    throt = hbPacket[2]<<8 | hbPacket[1];
}

```

```

#include <telemetryNode.h>
AlltraxNode testNode(&Serial); //Instance of the telemetry node

void setup() {
    testNode.begin(115200);
}

void loop() {
    /*
     * Add code to read peripherals
     * i.e. testNode.inVoltage = readVoltage();
     */
    testNode.update();
}

```

C. Telemetry Node Data

Each telemetry node works with a different set of data. Below is a list of the data sent and received for each node.

Node Name, Description	Data Points Received	Data Points Sent
Solar Controller Board <i>read the current output from the solar panels</i>	None	float outCurrent1: <i>current output from solar charger 1</i> float outCurrent2: <i>current output from solar charger 2</i>

Appendix F: Electrical System Data

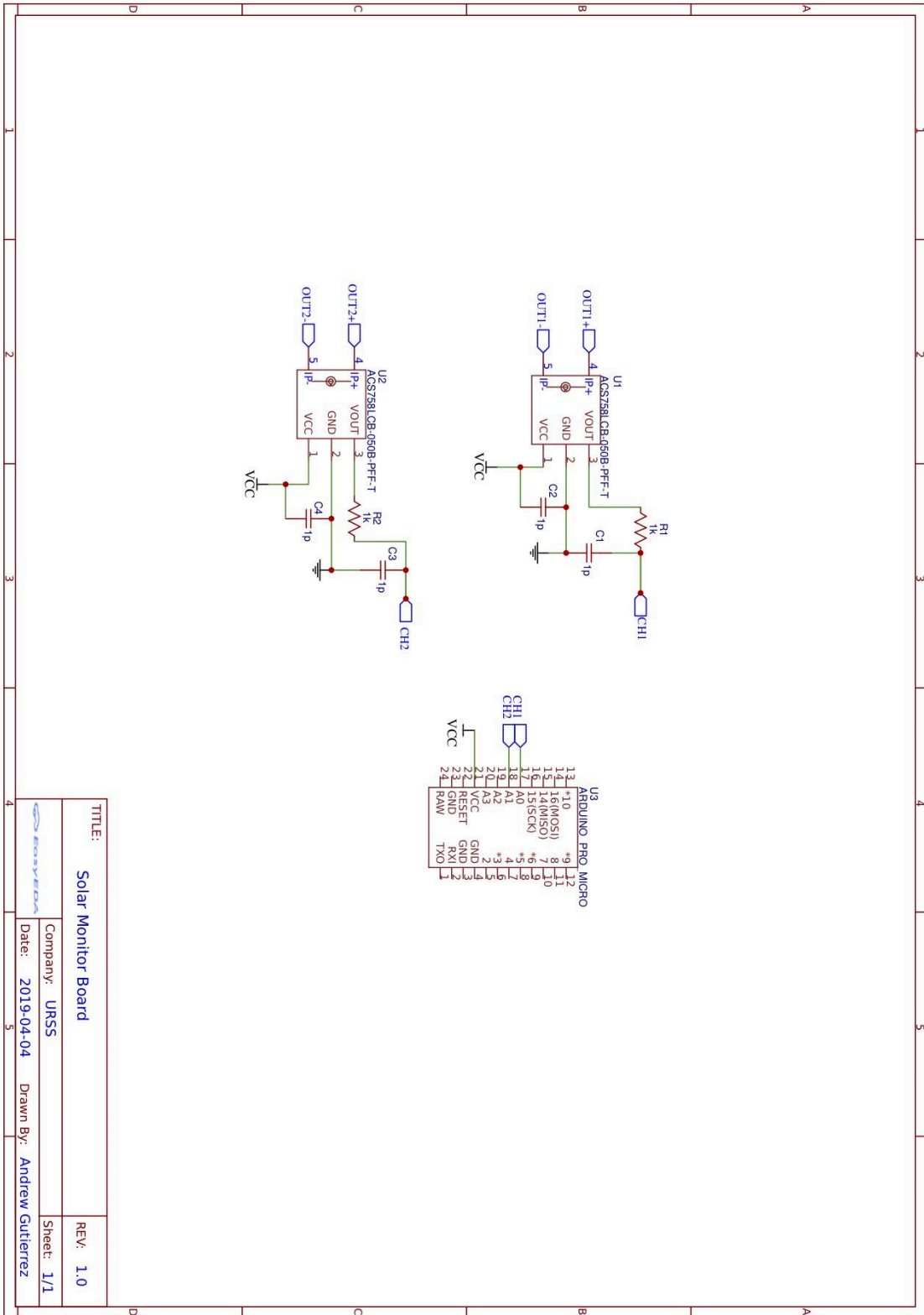

Schematic for the Solar Charger monitoring board.

TITLE:	Solar Monitor Board	REV:	1.0
Company:	URSS	Sheet:	1/1
Date:	2019-04-04	Drawn By:	Andrew Gutierrez

Appendix G: Power Electronics Data

A. Motor Specs

	Endurance Motor	Sprint Motor
<i>Model Name</i>	Alien Power Systems 6374S	Lynch Motor LEM-200 95
<i>Model Notes</i>	<i>Sensored BLDC Outrunner Motor</i>	<i>Axial-Winded Brushed DC Motor</i>
<i>Rated Voltage</i>	42v	48v
<i>Rated Torque</i>	9.5 Nm	28 Nm
<i>Rated Current</i>	80A	250A
<i>Rated Power</i>	2.8kW	10kW
<i>Peak Current</i>	--	400A
<i>Peak Power</i>	--	18kW
<i>Peak Efficiency</i>	95% (Estimation)	92%
<i>RPM at Rated Voltage</i>	2520	3888
<i>Speed Constant</i>	60 Rpm/V	81 Rpm/V
<i>Torque Constant</i>	0.012 Nm/A (Estimation)	0.113 Nm/A
<i>No Load Current</i>	0.65A (Estimation)	6A

B. Motor Controllers

	Endurance Motor Controller	Sprint Motor Controller
<i>Model Name</i>	VESC 4	Alltrax AXE4844
<i>Model Notes</i>	BLDC Sensored/Sensorless Motor Controller	DC "Series Wound" Brushed Motor Controller
<i>Rated Voltage</i>	8v - 60v	24v - 48v
<i>Rated Current</i>	50A	150A
<i>Peak Current</i>	240A (5 sec)	400A (2 min)
<i>Throttle Input Type</i>	USB Serial	Variable Resistor (5k Ohm)

C. Motor Datasheets



ALIEN POWER SYSTEM

APS 6374S Sensored Outrunner brushless motor 60KV 2800W

Description

SPECIFICATIONS:

- MODEL: APS 6374S
- KV: 60
- MAX POWER: 2800W
- TORQUE: 9.5 NM
- WIRE WINDS:
- MAX AMP: 80A
- MAX VOLT: 10S (42V)
- RESISTANCE:
- NO LOAD CURRENT:
- SIZE mm: 63 x 74 (without shaft)
- WEIGHT (g): 0,850
- SHAFT: 10mm with 3mm keyway
- Accessory pack: NO
- Internal PCB with 120 degree hall effect sensors

We can supply different motors, with custom power and KV.

If you need the transmission kit (timing belt, timing pulley, chain, etc) or keyway on the motor shaft or on the gears please feel free to send us a message. We will be happy to do help.

PLEASE NOTE: Alien Electronics LTD adopts a continuous development program which sometimes necessitates specification changes without notice. Pictures of products and information in the instructions manual are for reference only and can be changed without notice at any time. Colors of goods are subject to stock availability





LMC

GENERATING
MOVEMENT
EFFICIENTLY



MOTORS LEM-200

Overview

The LEM-200 is an axial gap DC brushed motor suitable for traction and industrial applications.

Example applications include grass cutters, Go-Karts, motorcycles, golf carts, scissor lifts, lightweight vehicles, boats and generators.

The LEM-200 is available in 95, 126, 127 and 135 strip armatures with magnet grade selection dependant on application.

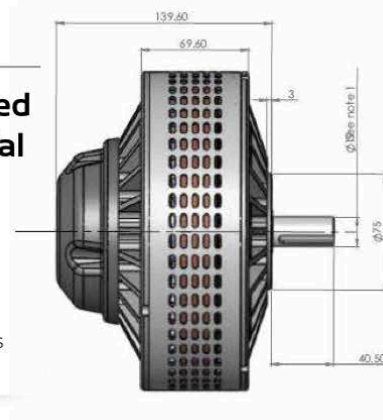

Features

- High efficiency (up to 93%)
- Interchangeable Shaft
- Available from 12 to 110v
- Lightweight design (11kg)
- Rugged Construction
- Speed proportional to voltage
- Simple electronic control
- CE Marked
- Long brush Life
- Ip20 rating

Typical Technical Data Curve

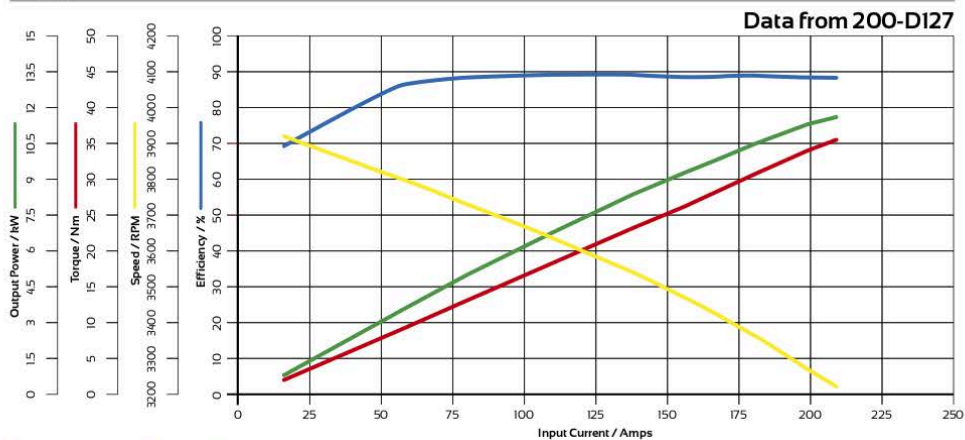

Important

Any model of the LEM-200 can be made up into the 2X2 version. This is 2 motors married together on a single shaft see 2X2 installation drawing for details on our website. This can also be supplied in a V-Twin layout which gives the same performance.

Technical Data

Motor	No Load Current	Torque Constant	Speed Constant	Armature Resistance DC	Armature Inductance @ 1kHz	Armature Inertia	Peak Power	Peak Efficiency	Peak Current	Rated Power	Rated Speed	Rated Voltage	Rated Current	Rated Torque
	A	Nm/A	Rpm/V	mΩ	μH	Kgm ²	kW	%	A	kW	Rpm	V	A	Nm
95	6	0.113	81	21.5	22	0.0238	18	92	400	10	3888	48	250	28
126	10	0.0737	105	175	6	0.0234	7.59	83	400	5.06	2520	24	270	19.2
127	5	0.15	54	22.5	23	0.0236	16.08	89	400	8.55	2592	48	215	31.5
D95B	6	0.14	76	20.5	11	0.0238	28.50	92	400	15.00	6000	72	210	30
DI26	5	0.0748	100	138	5	0.0234	11.14	81	400	6.91	3600	36	250	18.3
DI27	4	0.17	50	17.5	13	0.0236	25.38	92	400	12.56	3600	72	200	33.3
DI35	3.5	0.185	45	16.75	16	0.0236	29.04	93	400	14.39	3780	84	200	36.4
DI35 RAG	7.36	0.207	42	16.95	16	0.0238	34.32	93	400	16.84	4032	96	200	39.9
DI35 RAGS	7.45	0.21	40	16.95	16	0.0238	36.00	93	400	18.00	4400	110	200	42.0

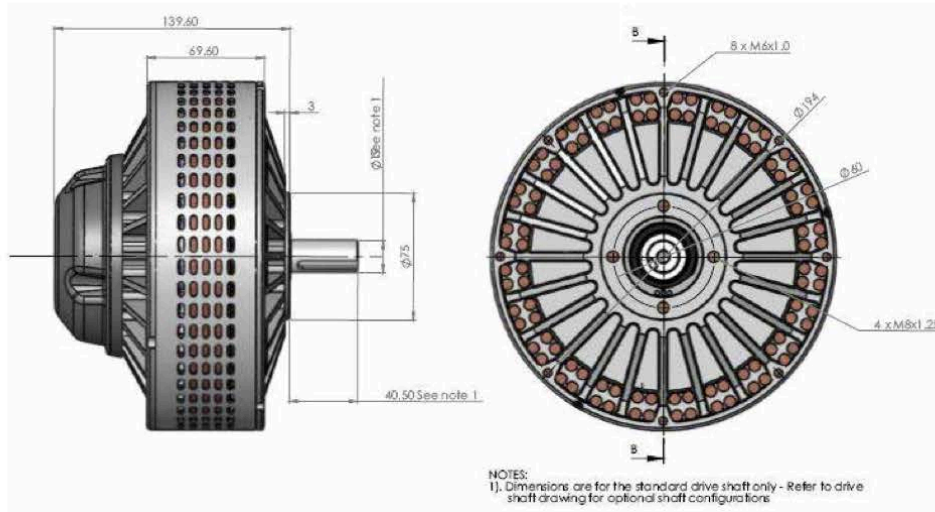

GENERATING
MOVEMENT
EFFICIENTLY

LCM Limited, Lynch Motor Company Ltd, Unit 27,
 Flightway Business Park, Dunkeswell, Honiton, Devon EX14 4RJ
 Tel: +44 (0) 1404 892940 Fax: +44 (0) 1404 891990
 email: sales@lmcltd.net www.lmcltd.net



D. Notes on Alltrax Throttle Control

Previously, our team used voltage-based throttle control, which had several difficulties. Since our system is 36v nominal, we needed an additional DC-DC converter to generate a 5v signal. The grounds on the input and output sides of many DC-DC converters are isolated, so when Alltrax reads the throttle value, an offset is present based on the difference between the ground references.

With the development of our telemetry system, we are using the telemetry network to transmit a digital throttle value. With the new system design, the throttle is sent as a data point into the telemetry system, and is then transmitted to the motor controllers over a serial connection.

Since the Alltrax cannot be controlled directly via serial data, we needed to create a circuit which would convert the throttle control signal to one of the inputs of the Alltrax controller. We chose to use a resistive throttle input. In this mode, the Alltrax measures the resistance across a lead and converts this 0-5k value to a throttle percentage. We used a digital potentiometer, which is an integrated circuit containing a resistor array mimicking an analog potentiometer. When a value is written over SPI to the digital potentiometer, it connects/disconnects a series of resistors to produce a given resistance value.

The digital potentiometer is built into a PCB with a controlling Arduino. This Arduino continually polls the telemetry network for throttle values, and writes the value over SPI to the digital potentiometer.

Appendix H: Drivetrain and Steering Data

A. Torqeedo Propeller Datasheets

TORQEEDO PROPELLERS								
	UltraLight 402 UltraLight 403 (C)	Travel 503/1003 (C)	Cruise 2.0/4.0 R/T Outboards - Splined Shaft Manufactured from 2017					
	Standard	Standard for Travel 503, 1003 (C)	Standard for Cruise 2.0 R/T		Standard for Cruise 4.0 R/T			
Part number	1912-00	1917-00	1901-00	1954-00	1955-00	1953-00	1933-00	
Propeller	v10/p350	v9/p790	v8/p350	v13/p4000	v20/p4000	v30/p4000	v19/p4000	
Diameter	200 mm (7.9")	292 mm (11.5")	300 mm (11.8")	320 mm (12.6")	320 mm (12.6")	300 mm (11.8")	300 mm (11.8")	
Pitch	8.2"	8.1"	10.7"	10.7"	13.5"	16.3"	10.4"	
Compatible models	UltraLight 402/403 (C), Wilderness Systems Helix MD	Travel 503, 1003 (Travel 503 standard: from 2014)	Travel 401, 801, 503 and 1003 (Travel 503 standard: before 2014)	Cruise 2.0/4.0 R/T splined (serial number >1705-XXXX)	Cruise 2.0/4.0 R/T splined (serial number >1705-XXXX)	Cruise 2.0/4.0 R/T splined (serial number >1705-XXXX)	Cruise 2.0/4.0 R/T splined (serial number >1705-XXXX)	
Features	-	-	-	More thrust for heavy displacement boats [approx. 12 km/h (7.5 mph)]	Planing with light boats [approx. 200 kg, 18 km/h (approx. 440 lbs, 11 mph)]	Planing with light boats [approx. 200 kg, 24 km/h (approx. 440 lbs, 15 mph)]	Weedless design	
	Cruise 2.0/4.0 R/T Outboards - Smooth Shaft and Actuation Pin, Manufactured between 2009 and 2016				Cruise 2.0/4.0 FP Fixed Pod Models			
	Standard for Cruise 2.0/4.0 R/T		Standard for Cruise 2.0/4.0 FP					
Part number	1916-00	1923-00	1915-00	1954-00	1962-00			
Propeller	v19/p4000	v30/p4000	v8/p350	v13/p4000	Folding propeller v13/v4000			
Diameter	300 mm (11.8")	320 mm (12.6")	300 mm (11.8")	320 mm (12.6")	330 mm (13.0")			
Pitch	10.4"	16.3"	10.7"	10"	9"			
Compatible models	Cruise 2.0/4.0 R/T with actuation pin (serial number > 5000)	Cruise 2.0/4.0 R/T with actuation pin (serial number > 5000)	Cruise 2.0/4.0 R/T with actuation pin (serial number > 5000)	Cruise 2.0/4.0 FP	Cruise 2.0/4.0 FP			
Features	Weedless design	For planing with light boats [approx. 200 kg, 24 km/h (approx. 440 lbs, 15 mph)]	More thrust for heavy displacement boats [approx. 12 km/h (7.5 mph)]	More thrust for heavy displacement boats [approx. 12 km/h (7.5 mph)]	For sailboats; composite hub (successor of 1932-00) - Aluminum anode for fresh water (included) Part number 1964-00 - Zinc anode for salt water (available for purchase) Part number 1965-00			
	Cruise 10.0 R Outboards			Cruise 10.0 FP Fixed Pod Models				
	Recommended for most applications			Standard for Cruise 10.0 FP				
Part number	1961-00	1938-00	1937-00	1937-00	1945-00			
Propeller	v22/p10k	v32/p10k	v15/p10k	v15/p10k	Folding propeller v15/p10k			
Diameter	320 mm (12.6")	320 mm (12.6")	320 mm (12.6")	320 mm (12.6")	380 mm (15.0")			
Pitch	13"	16.5"	11"	11"	10"			
Compatible models	Every Cruise 10.0	Every Cruise 10.0	Every Cruise 10.0	Every Cruise 10.0	Cruise 10.0 FP			
Features	Medium speed for planing or displacement	For planing with light boats [approx. 400 kg, 27 km/h (approx. 880 lbs, 17 mph)]	More thrust for heavy displacement boats [approx. 12 km/h (7.5 mph)]	More thrust for heavy displacement boats [approx. 12 km/h (7.5 mph)]	For sailboats; composite hub - Aluminum anode for fresh water (included) Part number 1947-00 - Zinc anode for salt water (available for purchase) Part number 1948-00			

B. Drivetrain CAD Drawings

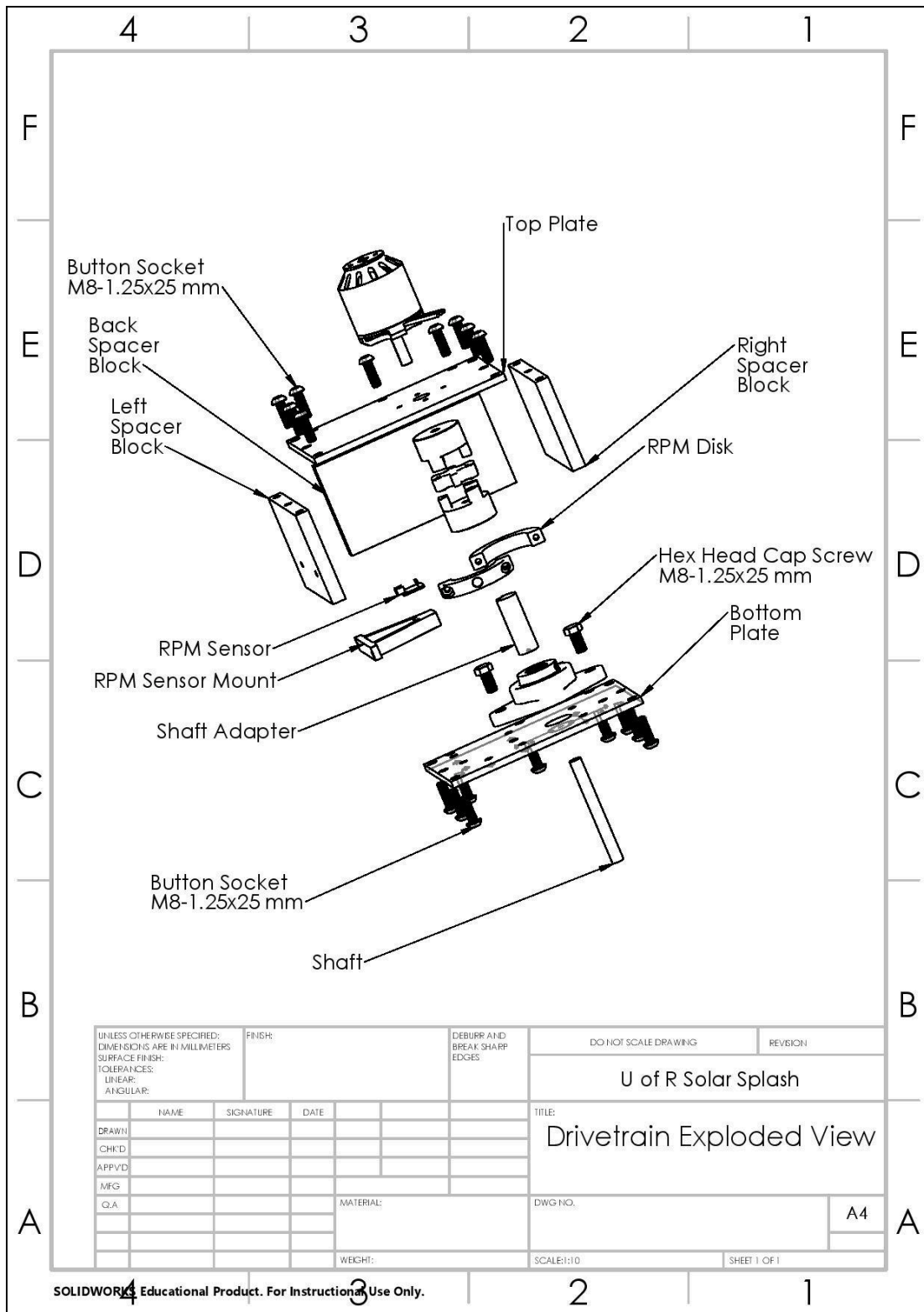

Exploded view of the drivetrain assembly.

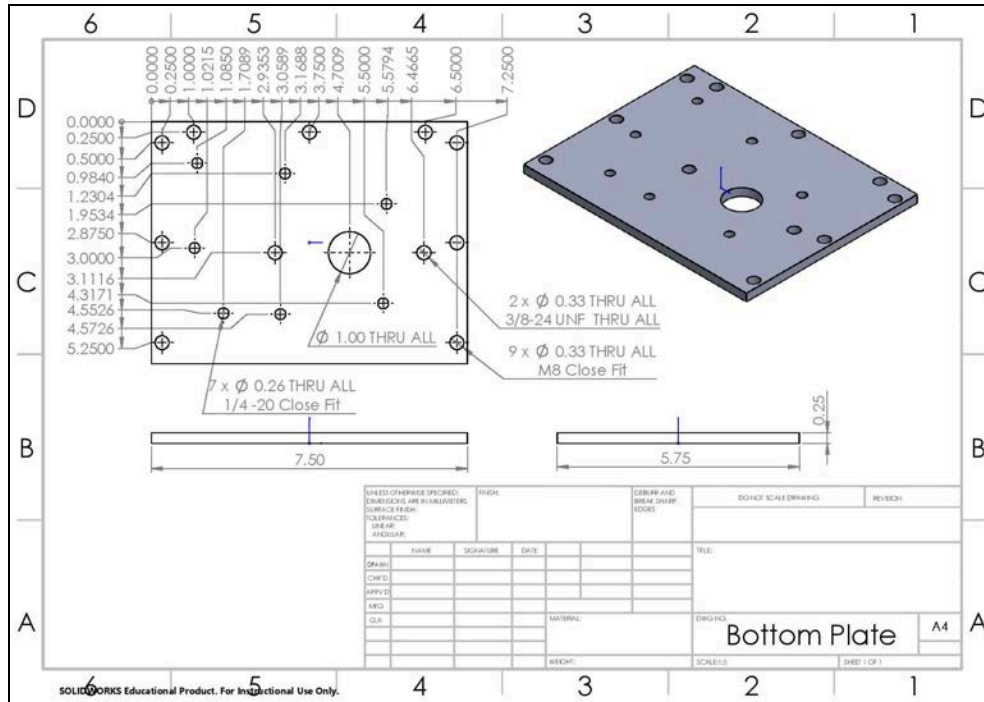

The drivetrain bottom plate bolts to the outboard motor unit.

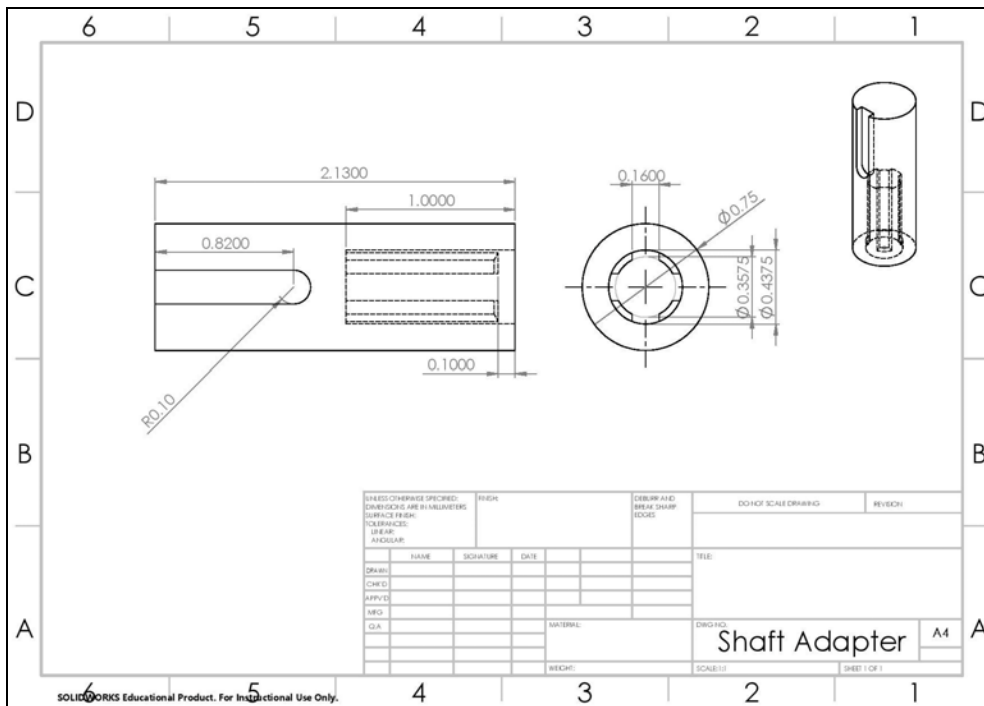

A shaft adapter is used to connect the upper unit to the 4-spline outboard motor shaft.

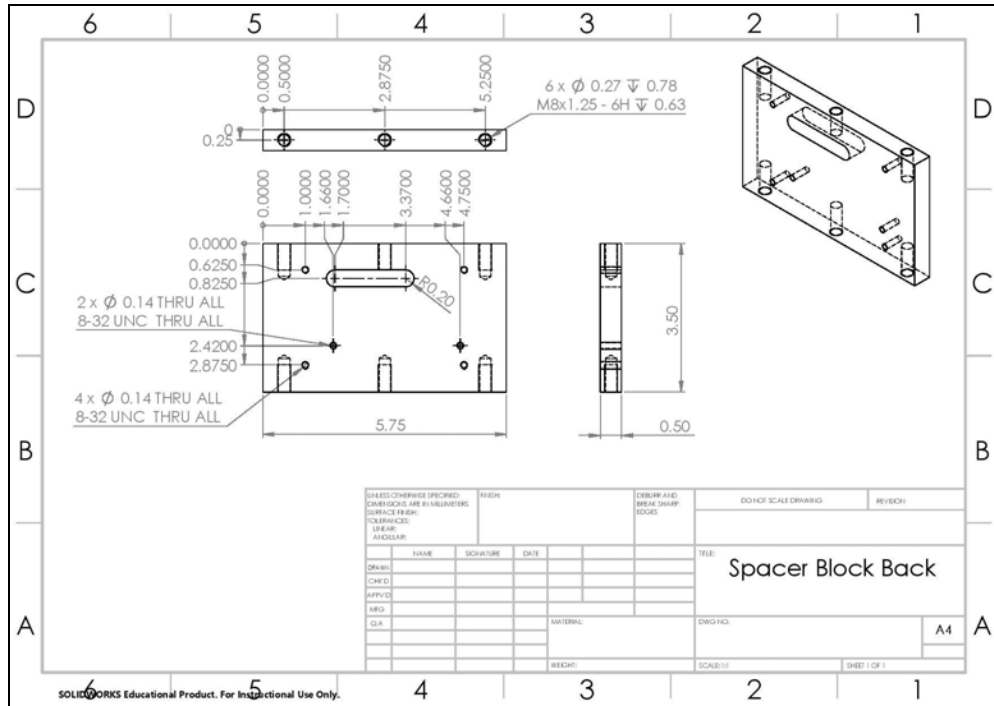

One of several spacer blocks used to construct the upper unit frame.

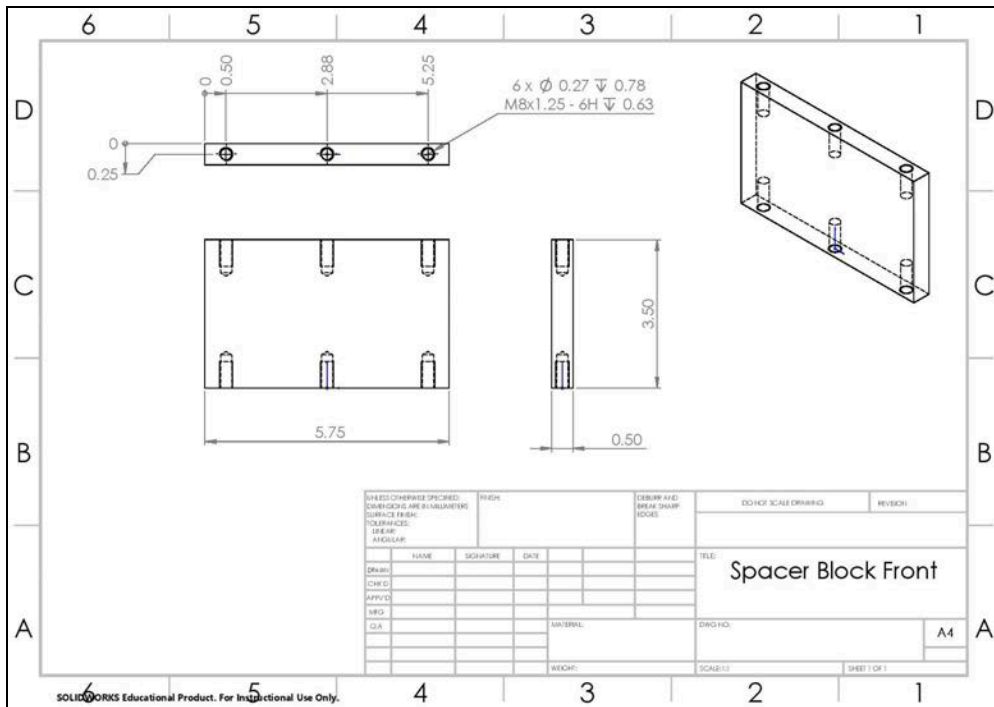

One of several spacer blocks used to construct the upper unit frame.

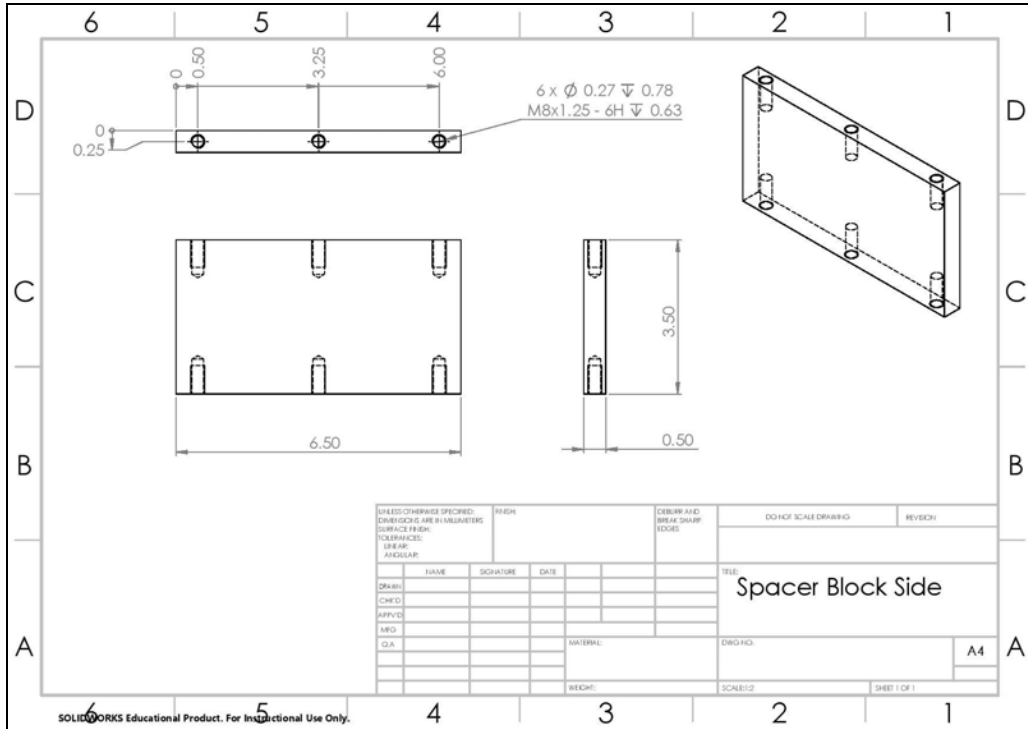

One of several spacer blocks used to construct the upper unit frame.

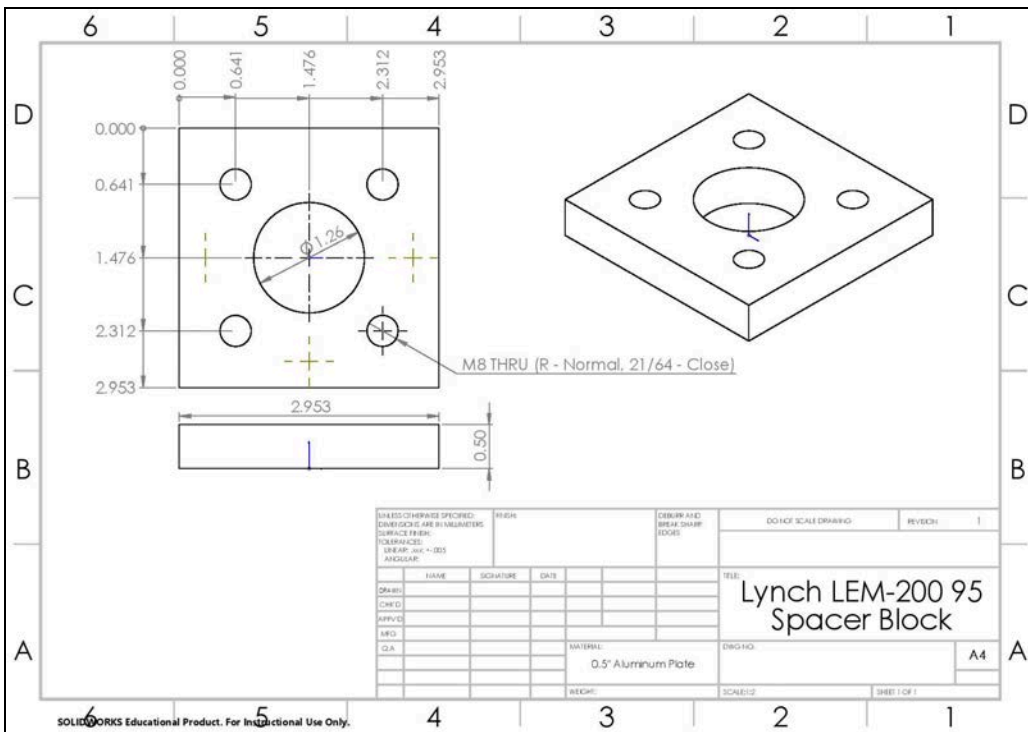

A spacer block that mounts under the Sprint motor adjusts the shaft's depth to accommodate the jaw coupling.

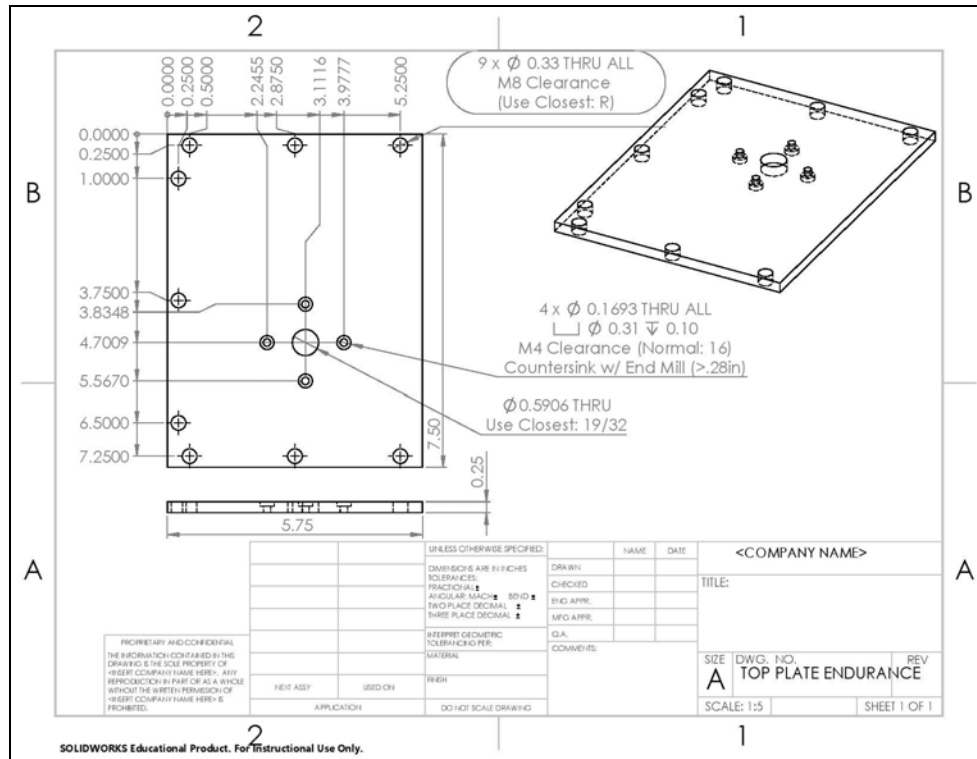

The upper plate used for the endurance motor. The endurance motor is permanently attached to this plate, and the plate is used to switch out motors.

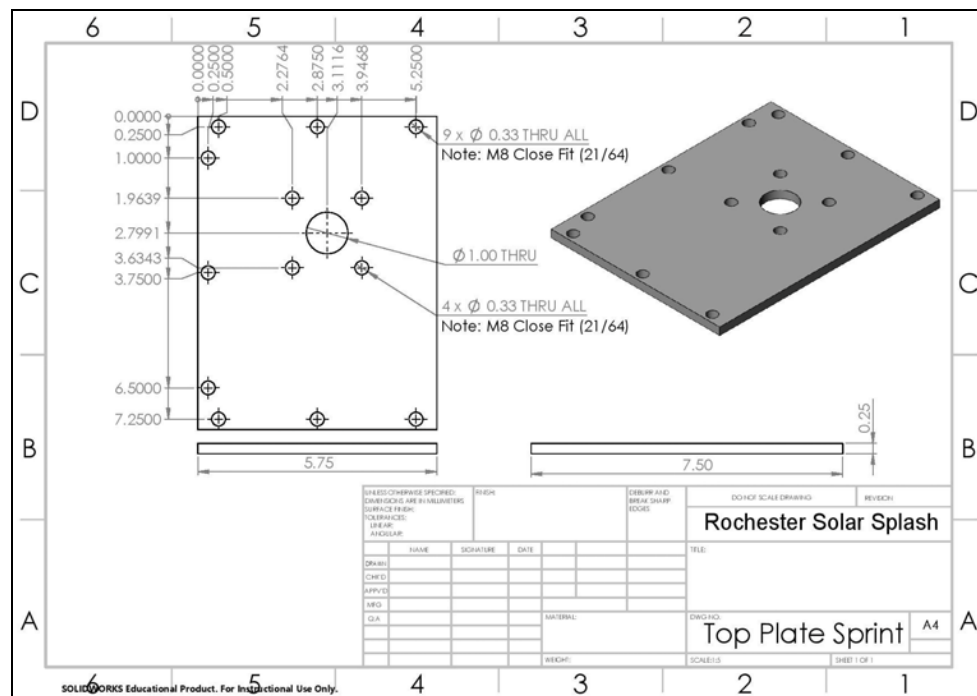

The upper plate is used for the sprint motor. Similarly, the sprint motor is permanently attached to this plate, and the plate is used to switch out motors.

C. Lower Unit Modifications

We modified the lower unit by removing the ventilation plate on the lower unit and filling the void. The ventilation plate prevents air from reducing thrust from the propeller at higher speeds, and we deemed this a reasonable sacrifice in order to allow for larger propellers. In the case that this becomes an issue, we can lower the outboard into the water and/or fabricate a custom ventilation plate that can be mounted higher to accommodate our larger propellers. After this modification, the outboard can now support propellers up to 14”.



Left: The modified outboard lower unit, with the ventilation plate cut back to allow for larger propellers. Right: The outboard motor with a frame of the upper unit, mounted on the boat hull.

Appendix I: Solar Energy System Data

A. Solar Charger Datasheets

GVB-8-WP

8A @ 12V, 24V, 36V, 48V

BATTERY CHEMISTRIES AVAILABLE:

The game changer.
All weather charging, in any condition! The waterproof GVB charge controller with MPPT allows a lower- voltage solar panel to charge higher-voltage batteries. Want to charge a 36V battery with a 60-cell solar panel? No problem. A 48V battery from a 12V panel? With 99% peak efficiency, they are the industry's most efficient voltage-boosting controllers. True MPPT delivers consistent performance! The advanced electronics inside the controller are encased in a proprietary potting compound making them ideal for golf-cart, marine, and vehicle applications where they are exposed to the elements.

- **36V battery charging with a 325W grid-tie panel.**
Genasun's unique GVB-8 Boost controllers enable 36V battery charging from a single 325W grid-tie panel. This revolutionary controller boosts panel voltage up to the battery voltage - increasing system efficiency while reducing cost per Watt.
- **Maximum power from each panel.**
Like micro-inverters, the GVB-8 Boost controller is designed for a single panel. This configuration maximizes the power output from each panel. The total array power can easily scale up by adding panels and controllers in parallel.

Great For:

- Golf carts
- Marine & RV
- Telecom
- Remote water pumps
- Remote switches
- Mobile signage

FEATURES:

- Waterproof
- 99% peak efficiency
- Ultra-fast true MPPT Tracking
- Electronic-overload protection
- Electronic reverse battery protection
- Over-temperature-protected with current-foldback
- Automatic recovery from fault conditions
- Shade-tolerant tracking
- No radio frequency noise
- Wire leads for easy installation

SPECIFICATIONS:

8A @ 36V, 48V

GVB-8-WP

Max Panel Power:	105W - 350W
Continuous Current Rating:	8A*
Nominal Battery Voltage:	12V, 24V, 36V, 48V
Recomm. Max Panel Voc at STC:	50V

*Panel ratings have increased since we designed the GVB. Although we don't believe in changing specifications without a corresponding engineering change, based on both our customers' experiences over the years as well as the headroom we designed into the GVB, we feel comfortable recommending the GVB for panels with Imp up to 8A.

CE FC

ROHS COMPLIANT

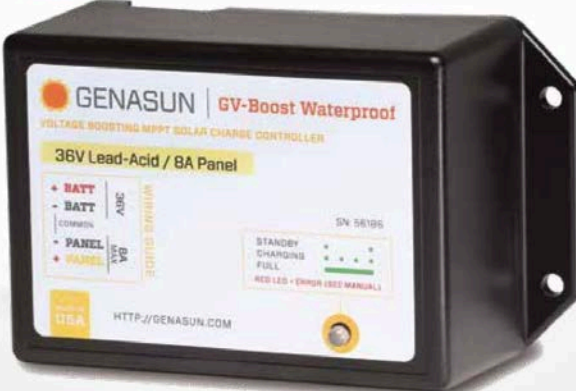

B. Solar Panel Datasheets



SBM 258W Module

Specifications

Maximum Power (Pmax)	258W
Rated Voltage (Vmp)	31.62V
Rated Current (Imp)	8.16A
Open Circuit Voltage (Voc)	37.38V
Short Circuit Current (Isc)	8.72A
Max Fuse Rating	15 A
Weight lbs (kg)	27 lbs (12.3kg)
Power to Weight Ratio: Watts Per Lb/(kg)	9.5W (21W)
Dimensions (inches)	38.67 x 65.06
Module Area ft ² (m ²)	17.3 ft ² (1.61 m ²)
Power Output: Watts per ft ² (m ²)	14.9W (160.5W)
Diodes per module	4
Mono Crystalline Solar Cells	60 cells
Cell Efficiency	~19%

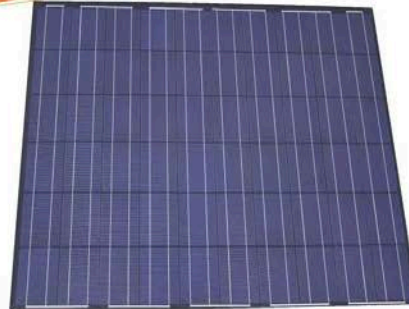

Available with black or white back sheet behind cells
*Shown in black

SBM Solar, Inc., founded 2002, is one of the first manufacturers of a UL certified, non-glass, non-EVA and crystalline PV solar module. The module's multi-layered structure provides excellent environmental and chemical protection, better moisture resistance. The encapsulating package is the combination of a Fluoropolymer film provided by *DuPont* and the adhesive encapsulating material, by *The Dow Chemical Company*, performs superior comparing to commonly used EVA. This non-glass PV module is manufactured in the USA.

LIGHTWEIGHT

SBM's solar modules are 40-50% lighter than glass panels. This makes easier for shipping, handling, and installation, and save cost.

SHATTERPROOF/DURABLE

When the glass module is shattered, its entire module will be subsequently loss of power. SBM's non glass modules are completely shatterproof. It is able to withstand the hazardous environmental conditions (hail, rain, wind, heat, cold, and humidity). They are **IEC 61215** certified for hail impact resistance.

HIGH TRANSPARENCY / LOW GLARE

Blinding glare associated with glass panels can be dangerous and unsafe in certain applications. SBM's solar module utilizes its advanced material property to reduce the reflection. This makes SBM solar modules perfect for applications where glare becomes a critical safety issue such as in military, airport, and highways.

HIGH EFFICIENCY C-SI SOLAR CELLS

SBM Solar modules have over twice the wattage per

square foot compared to thin film. They have over 19% cell efficiency and 14.7 watts per square foot compared to thin film's 6-8% module efficiency and 5 watts per square foot.

Besides our standard panels, SBM also develops customized and / or building integrated solar applications. This provides architects and engineers optimal architectural flexibility which preserves design and aesthetic integrity.

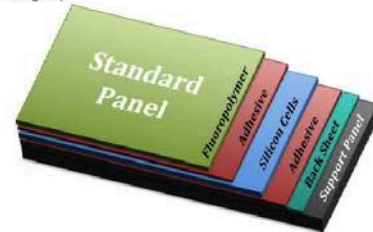

All components are made and manufactured in USA

WHY SBM SOLAR?

- Lightweight
- Shatterproof
- Strong & Durable
- High Transparency
- Low Glare
- High Efficiency
- MADE IN USA

UL CERTIFICATION

SBM's 140W non-glass, crystalline PV, rigid modules are UL1703 certified

IEC CERTIFICATION

SBM 140W Module has been certified for Hail Impact Resistance based on the IEC61215 Testing Standards from TUV Rheinland PTL, LLC

For more information please visit us at: www.sbm-solar.com

SBM SOLAR, INC.

8000 Poplar Tent Rd
Suite C
Concord, NC 28027
Phone 704.788.2881
Fax 704.793.1909

GO GREEN & DEMAND THE BEST!

C. Explanation of Step-Down vs. Boost MPPT Chargers

The power output from a solar cell can be defined by an IV curve showing the relationship between the operating voltage and the output current^[6]. Two defining values for a solar panel are its short circuit current, I_{sc} , and its open circuit voltage, V_{oc} . The short circuit current is the maximum output current of the panel but exists at 0v, meaning the total power output is zero. Similarly, the open circuit voltage is the maximum voltage difference across the panel, but since the current is zero at this point, the total power output is zero. The best output lies on the curve somewhere between these two points.

Altering the load on the solar panel can change the position on the IV curve. The point where power is maximized is the “Maximum Power Point,” which is some point (V_{mp} , I_{mp}) on the IV curve where $P=IV$ yields the maximum power. An MPPT algorithm tracks this point to maximize output from a panel, as seen in the chart below.

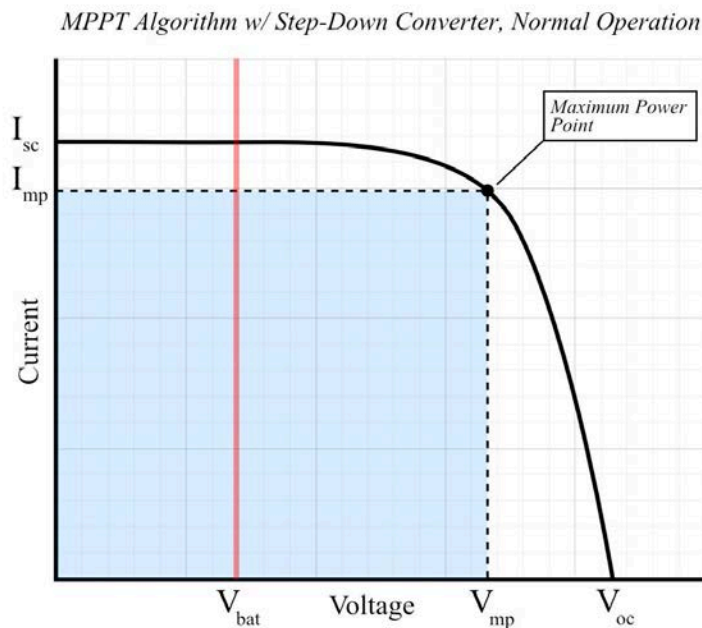

The maximum power point is some point (V_{mp} , I_{mp}) on the curve where $P=IV$ yields the maximum power. Under normal operation, $V_{bat} < V_{mp}$, the step-down charger works normally.

If the MPPT charger uses a step-down converter and the battery voltage (V_{bat}) is greater than the maximum power point voltage (V_{mp}), the power is restricted as the converter can only operate at input voltages greater than or equal to the output voltage. This is the case with our solar panels: $V_{mp} = \sim 31\text{v}$, and $V_{bat} = \sim 42\text{v}$ during charging. This case is seen in the chart below, where the voltage is clamped to the lowest possible value, the battery voltage.

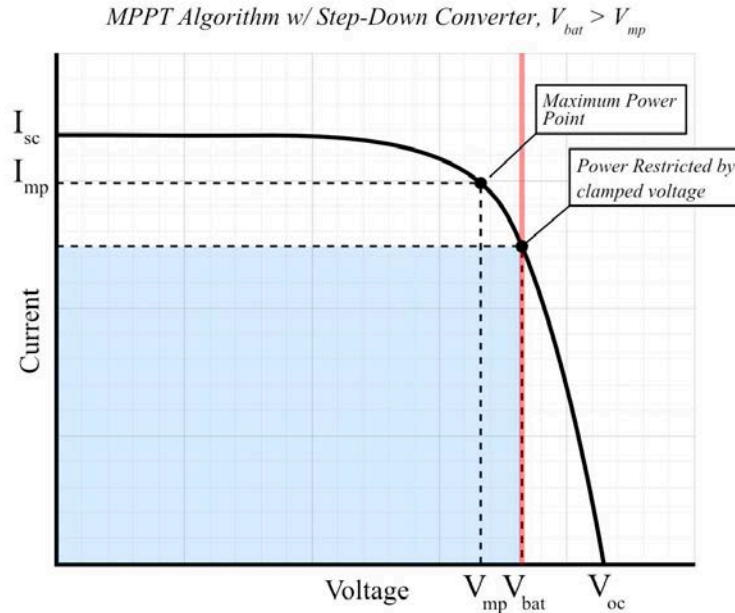

In this chart, the battery voltage is greater than the maximum power point voltage. Since the step-down converter cannot convert a lower voltage input to a higher output, the voltage is clamped to the lowest possible value, which is the battery voltage.

With a boost converter, the DC/DC converter can operate at voltages up to the battery voltage, which better matches our solar panels and batteries without causing voltage clamping that restricts the output power.

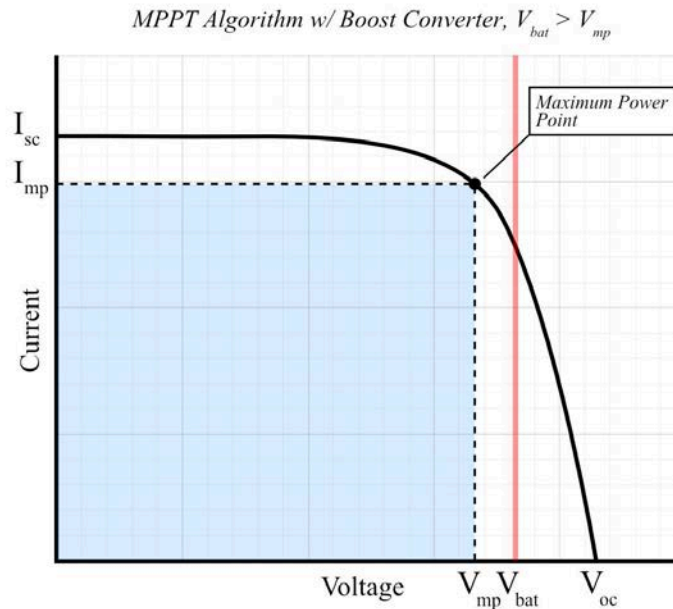

MPPT algorithm with a boost converter, where $V_{mp} < V_{bat}$. The maximum power point is reached because the boost converter is able to use any solar panel voltage below the battery voltage. This matches our solar configuration.

Appendix J: Hull Design Data

A. Hull Modification Process

Below is a selected sequence of pictures from this year's hull modification process.

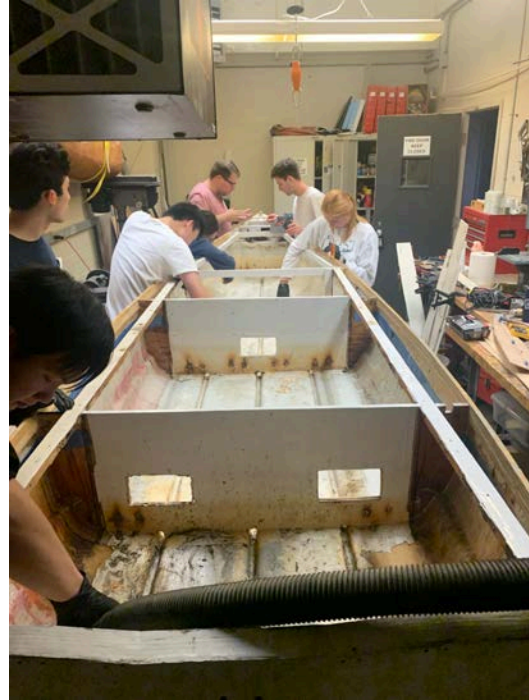

Left: The hull is left outside. The boat's current state is salvageable. Right: Hull modification work begins. We started by removing the benches. The wood used to build the benches was saturated with water, and water pooled on the inside of the sealed compartment.

The entire interior of the hull was sanded to remove any remaining wood and fiberglass. This left just the fiberglass shell, which could now be reinforced.



Left and right: Stripped boat. Began adding in stringers with marine plywood.

We mounted the transom and stringers to the hull using fiberglass strips and epoxy.

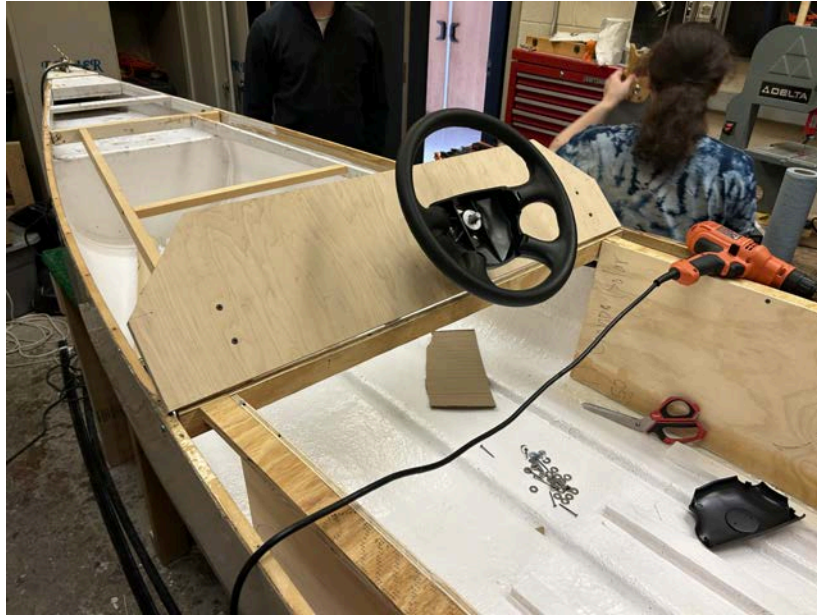

Re-epoxy and paint the boat—A new internal steering structure was built.



Stringers and steering structures are in. Solar Panels have been placed to demonstrate their placement. The solar panel stands are next to be built.

Next, we constructed the remainder of the hull reinforcement, made up of the wooden frame and lightweight plywood enclosing the buoyancy boxes.

All joint locations were reinforced with marine epoxy and fiberglass to secure the wooden panels to the boat and to each other.

We painted all the visible surfaces with marine top coat paint. The surfaces inside the buoyancy boxes will be covered with floatation foam, and have been encapsulated with epoxy.

Next, we plan on putting a second coat of paint on the interior, and adding a flexible rubber “rub rail” along the gunwale.

B. Hull Design History

Below is a summary of our team’s research into the hull design process. Although we did not build our own hull this year and elected to use a premade hull, the knowledge gained from this process will be of use in future years.

2010 - 2011



The team’s first hull was a premade fiberglass cargo canoe, the Ungava Bay 16, manufactured by Great Canadian Canoes and purchased by the team during their first year of existence. This hull is a square-stern canoe, a displacement hull with a weight of ~120 lbs and a carrying capacity of ~800 lbs.^[7] High stability and effectiveness at low speeds, poor performance in the sprint. This hull was modified this year and serves as a good base hull for our team.

2011 - 2014

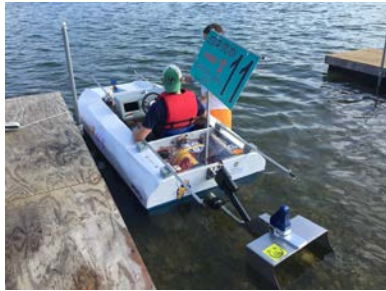

This design, the first fiberglass boat the team manufactured, was a hybrid planing/displacement hull with a triangular design. Lack of experience in fiberglass construction and a fiberglass-cloth-based process made this hull extremely heavy and unwieldy, but it served as valuable experience in learning the techniques of hull construction.

2015 - 2016

The team will manufacture the second fiberglass boat with a “pickle fork” trimaran design. While creative, the short, wide hull caused a large amount of drag. Additionally, the trimaran hull that this design was based on is intended for high-speed racing boats, which benefit from the tracking ability, a benefit that did not apply to our team. The hull suffered from cavitation issues due to the wide transom, necessitating a propeller far back from the transom of the hull.

2017

This hull was our team’s first attempt at cedar strip hull construction. This hull was extremely light when unloaded (~20 lbs). The hull had stability issues; the lack of a hard chine and a very round hull profile meant the center of gravity was very high, and no significant righting moment was created when the hull was tipped over. Our team was required to include pontoons, which caused a large amount of drag. The cedar strip hull construction process that we learned from the development of this hull is likely to be used in the future due to its simplicity.

C. Hydrostatics Testing Program

As our team experimented with modeling hull designs, we needed to quickly determine the hydrostatic properties of the hull models we developed. Waterline position, stability curves, center of mass, and other properties are valuable during the hull design process as basic metrics for how seaworthy the hull will be.

While programs such as ANSYS Fluent are powerful, determining these values through a full fluid simulation is time-consuming and complex. Design software such as Rhino/Orca provides utilities to calculate these values for a hull model, but our team would like to maintain our use of Solidworks for all design work.

The team expressed a need for a system that could quickly calculate the following hydrostatic properties for Solidworks-based hull models:

- Total water volume displaced
- Waterline position
- Static Pitch/Roll
- Hull stability curves
- Center of Gravity

Based on this need, a team member built a tool for calculating boat buoyancy, stability, and waterline. This tool, called “Float-Util,” can quickly import a model and perform analysis, providing hydrostatic information. Since our team did not end up designing and building a boat hull this year, we did not have a chance to use this tool extensively. However, we can now perform these calculations quickly, which will assist our team in the future.

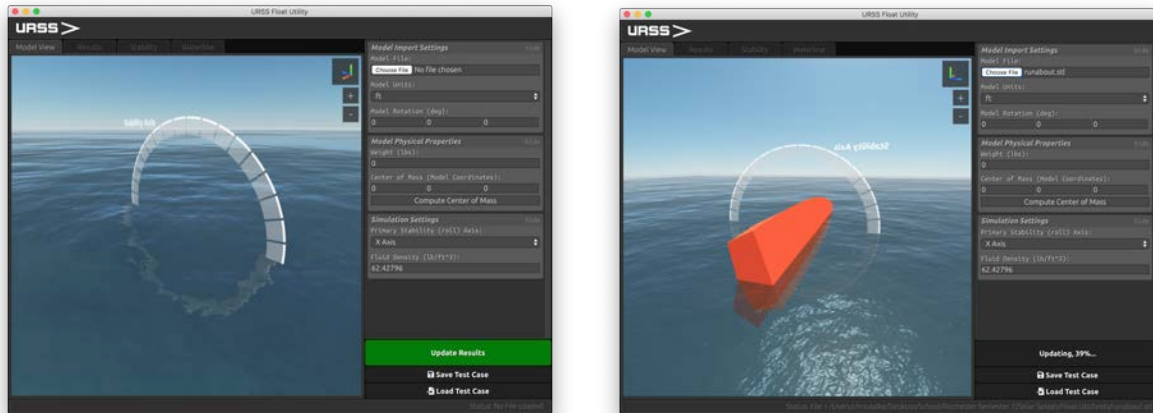

Screenshots of the Float-Util program in action; pictured right is a boat hull being simulated for roll stability.

1) Workflow: The workflow for using the tool is as follows:

- 1) A user exports their Solidworks-created hull model to an .STL file
- 2) In Float-Util, they select the model, enter the desired weight
- 3) The user can optionally provide a custom COG. If nothing is specified, the COG of the model is automatically calculated.

Once a model is loaded, any configuration options (weight, COG, etc.) will be modified to update the output to instantly reflect the new hydrostatic properties. Using this tool, a hull designer can quickly view the consequences of a modification to the hull profile.

2) Mesh Volume & Center of Mass Calculation: The simulation requires calculations of the volume and center of mass for the split hull meshes. For simplicity, we assume that all meshes are enclosed and made entirely of triangle polygons.

The volume and center of mass calculations both use a similar technique: Construct a tetrahedron from the polygon to the origin of each triangle. The volume and/or center of mass of the tetrahedron can be calculated. Then, based on the direction of the triangle normal (facing towards/away from the origin), the values are added or subtracted to a global accumulator.

If the triangle faces away from the origin, this represents the solid body's beginning, or "outside," and we add the volume to the accumulator. If the triangle faces towards the origin, this represents the end, or "inside" of the solid body, and we subtract the body spanning from this triangle to the origin.

After all the triangles have been iterated through, we are left with values representing the center of mass and volume of the entire body.

3) Iterative Simulation: To calculate the boat's waterline position, an iterative simulation is run, which "floats" the boat in the water using its center of mass, the center of buoyancy, and net buoyancy. At each step of the simulation, two operations are performed, which control the position and rotation of the floated body:

- The volume calculation is used to obtain the mass of fluid displaced by the underwater hull segment. The hull weight is subtracted by this value to obtain a delta, which is applied to the boat's Y coordinate. This "floats" the boat vertically, finding an equilibrium for displacement.
- The center of mass calculation is used to obtain the centers for the full and underwater bodies. The center of mass of the underwater buoyancy, also known as the "center of buoyancy," is calculated. A moment is calculated and applied, rotating the hull to find a stable angle.

This simulation is iterated until both the position and rotation deltas are significantly small.

Appendix K: Project Management Data

A. Executive Board Roles

The executive board is made up of the following roles, elected yearly:

- **President:** Presides over meetings, maintains organization within the club and guides the club's overall mission.
- **Head Engineer:** This person oversees the boat's building and its various systems and ensures the engineering teams have the resources needed to succeed.
- **Business Manager:** This position is responsible for managing all finances and transactions and interacting with club sponsors and the school's departments.
- **Project Managers:** Responsible for their specific project and keeping a log to report back to the Head Engineer.

B. Budgeting Documentation

Below are the spreadsheets we used to track expenses for our team. We tracked each purchase using an Excel spreadsheet and tabulated our total expenses in a cumulative purchase log, as shown below. For each purchase, we used a template form that included details about the items, where they were purchased, their cost, and our funding source. The business manager maintained these spreadsheets.

Solar Splash Purchases					Expense Summary		
Purchase Log Sheet							
Purchase Name	Link to Purchase Log	Funding Source	Total Cost	Status	Spent	Budget	Remaining
September Various Purchases	https://docs.google.com/spreadsheets	Hajim	\$435.34	Completed	Hajim Expenses		
Lynch Motor	https://docs.google.com/spreadsheets	Reimbursement	\$1,211.79	Completed	\$5,094	\$6,500	\$1,406
Solar Splash Fall GIM	N/A (\$40 at Cam's pizza)	SA	\$34.97	Completed	SA Expenses:		
Solar Splash Spring GIM	N/A (\$40 at Cam's pizza)	SA	\$40.00	Completed	\$3,787	\$3,870	\$83
Competition Registration	https://docs.google.com/spreadsheets	SA	\$750.00	Completed	Other Expenses (Out of Pocket):		
Hotel Accommodations	https://docs.google.com/spreadsheets	SA	\$2,071.59	Completed	\$0	\$0	\$0
Rental Truck	https://docs.google.com/spreadsheets	SA	\$890.00	Ordered			
Spring Purchase 1	https://docs.google.com/spreadsheets	Hajim	\$1,233.40	Completed			
Lowes Reimbursement 1	N/A	Hajim	\$203.31	Completed			
Lowes Reimbursement 2	N/A	Hajim	\$195.22	Completed			
Hull Construction Supplies	https://docs.google.com/spreadsheets	Reimbursement	\$392.35	Completed			
PEI-Genesis connectors	https://docs.google.com/spreadsheets	Reimbursement	\$295.52	Completed			
Spring Purchase 2	https://docs.google.com/spreadsheets	Hajim	\$571.12	Completed			
Spring Purchase 3	https://docs.google.com/spreadsheets	Hajim	\$555.57	Completed			
Spring Purchase 4	https://docs.google.com/spreadsheets	Hajim					

The cumulative purchase log for the year shows all transactions and the remaining budget.

Solar Splash Purchase Sheet					
Purchase Name Here					
Completed: No			Purchase Method: Hajim		
			Purchase Number:		
Item Name	Details	Item Link	Quantity	Cost per Item	Cost
					\$0.00
					\$0.00
					\$0.00
					\$0.00
					\$0.00
Total Cost					\$0.00

A template used for individual purchases. To use this, the team fills out the list, and the business manager adds it to the cumulative purchase log. As the purchase is performed and tracked, the business manager updates the status of this purchase sheet and the master sheet.

Appendix L: Power Budget

The power budget is an estimate of how much power we have available to use during endurance mode. The goal is to allow our boat to drive continuously throughout the entire endurance race, with the batteries ending the race drained. We started by finding our batteries' effective continuous amperage capacity to calculate our power budget. Over the course of 2 hours, the endurance heats up, and the batteries can discharge 16.59A to reach 10.5v. In order to best preserve our batteries and prevent damage to their capacity, we decided not to discharge them past 10.5v.

Constant Current Discharge Characteristics

F.V/Time	5MIN	10MIN	15MIN	30MIN	1HR	2HR	3HR	4HR	5HR	8HR	10HR	20HR
9.60V	157.6	116.0	86.54	45.21	28.09	17.34	11.78	9.50	7.89	5.20	4.68	2.48
10.0V	153.0	110.4	84.76	44.63	27.71	16.99	11.57	9.37	7.82	5.18	4.64	2.43
10.2V	148.5	106.5	83.43	43.95	27.45	16.81	11.46	9.27	7.77	5.13	4.59	2.39
10.5V	133.3	98.26	79.44	42.74	27.11	16.59	11.36	9.14	7.70	5.08	4.55	2.34
10.8V	120.3	89.60	73.23	41.33	26.74	16.46	11.23	8.82	7.66	5.06	4.50	2.32
11.1V	102.7	80.08	65.68	39.76	26.10	15.79	11.01	8.70	7.61	5.02	4.45	2.22

Constant Power Discharge Characteristics

F.V/Time	5MIN	10MIN	15MIN	30MIN	1HR	2HR	3HR	4HR	5HR	8HR	10HR	20HR
9.60V	1662	1235	943.4	517.5	325.5	203.2	138.7	113.7	94.50	62.22	56.15	29.86
10.0V	1630	1198	928.3	512.2	322.5	200.7	136.7	112.1	93.65	61.98	55.71	29.34
10.2V	1611	1166	917.8	507.7	320.6	199.3	136.1	111.1	93.09	61.51	55.22	28.80
10.5V	1467	1086	875.5	497.4	318.6	196.8	135.0	109.6	92.34	60.99	54.67	28.26
10.8V	1336	1001	809.2	485.6	314.5	195.3	133.5	105.9	91.92	60.72	54.13	27.98
11.1V	1173	904.9	728.4	472.3	309.8	188.0	131.2	104.4	91.58	60.30	53.54	26.98

(Note) The above characteristics data are average values obtained within three charge/discharge cycles not the minimum values.

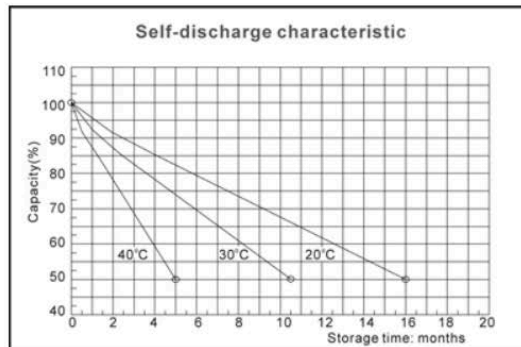
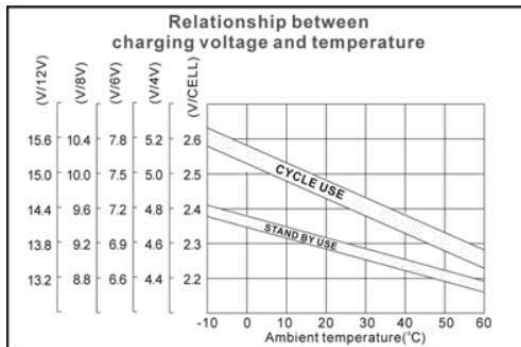
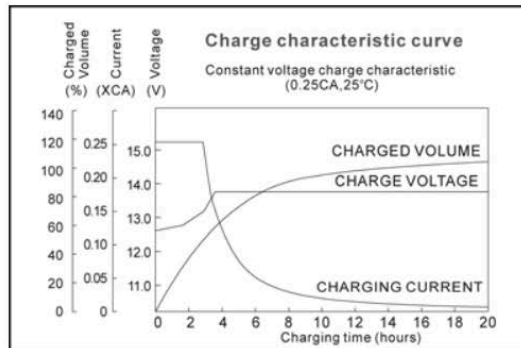
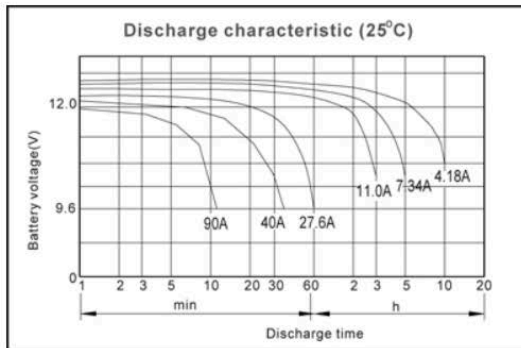

Constant current discharge information for the 45 UPS battery, provided by the manufacturer.

Our solar panel configuration is rated for 512W. Ideally, on a partly clouded day, our panels will produce 80% of this rating for a total of 410W. At 36v, 410W pushes 11.4A of current. Combining the solar panel and battery currents, we can achieve 28A.

However, in experimental testing of our solar panels, we consistently achieved near 60% solar efficiency or approximately 290W solar panel output. These trials were performed in the early spring and are an effective conservative estimate. At this level of efficiency, our panels push 8A of current, affording us 24.6A total.

Appendix M: Propeller Data

A. Validating Testing Methods

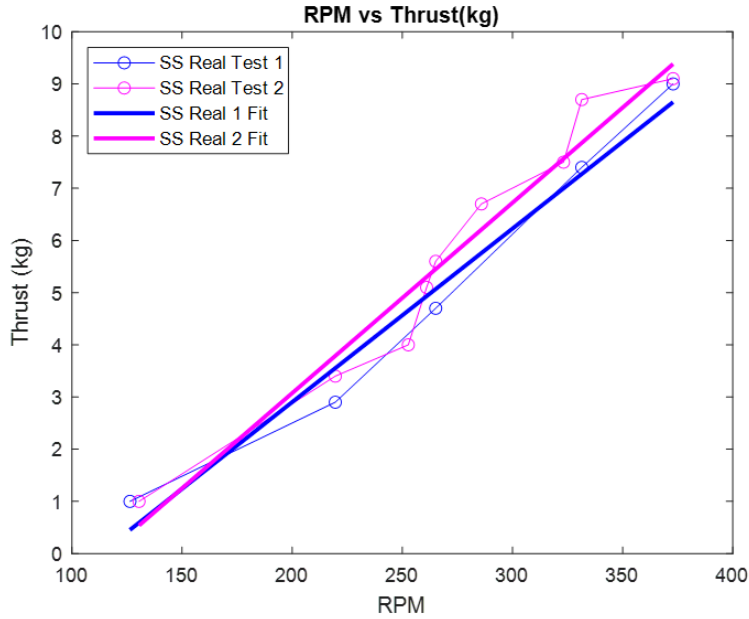

RPM vs. Thrust results for two different testing sessions on the real Solar Splash propeller.

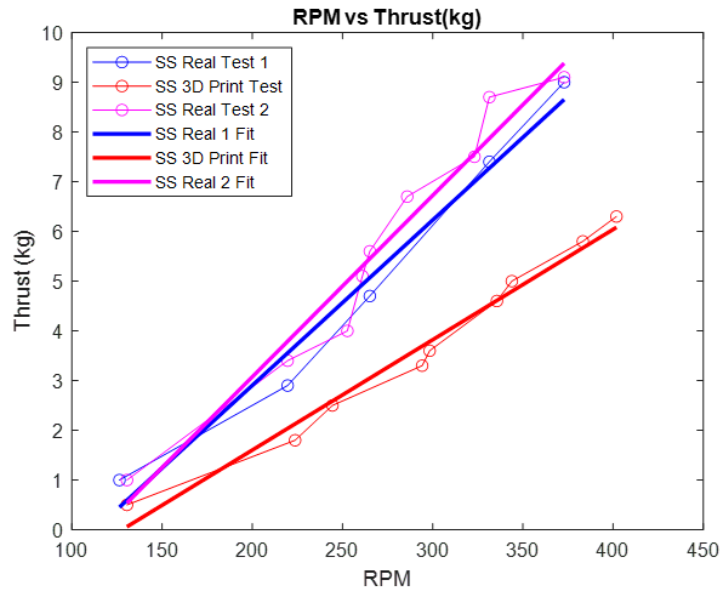

Compare SS 3D printed to SS actual testing.

B. Simulation Results

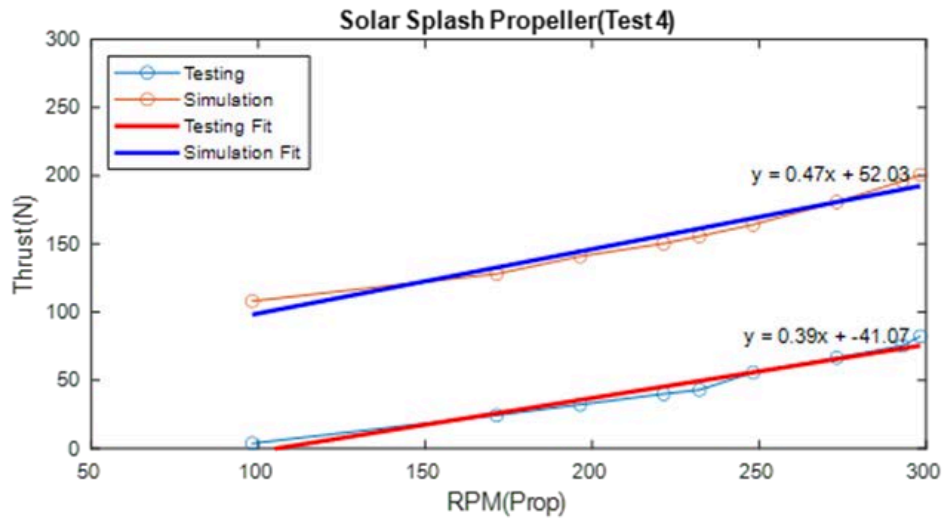

Correlating SS Simulation to SS testing data.

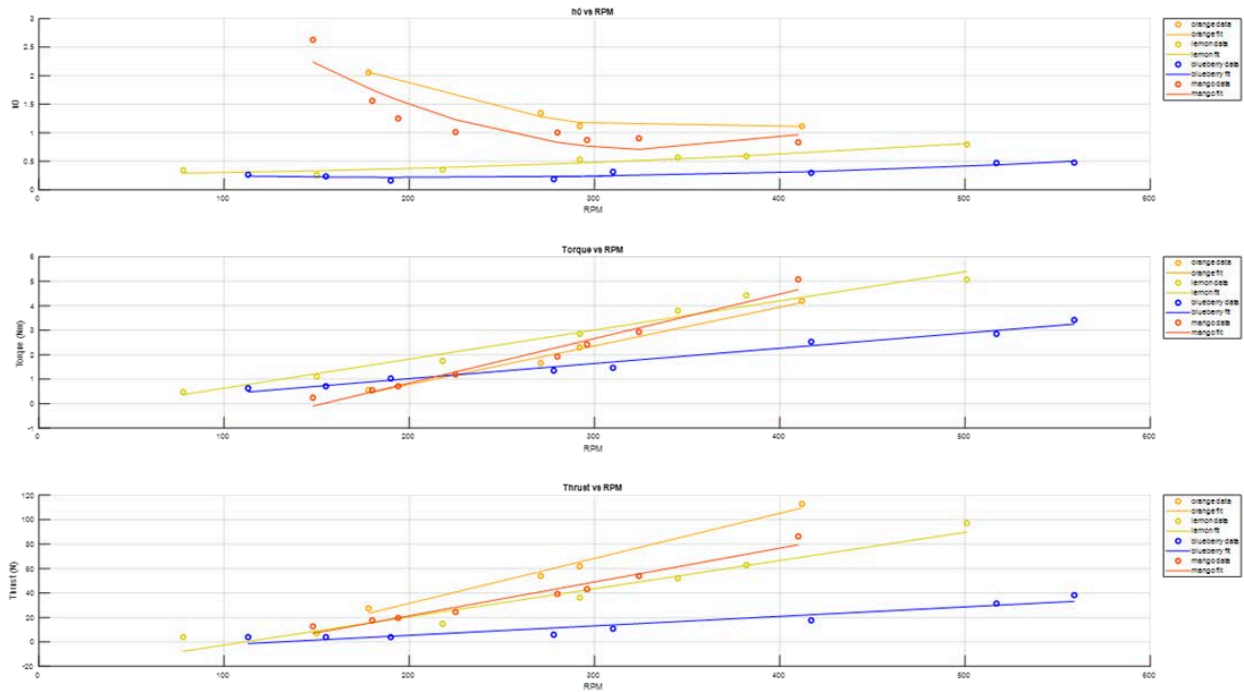

Comparing all the different propellers against each other.

C. Modeling and Optimization



3D printed models and Static wireframe view of rotating region geometry in NX.

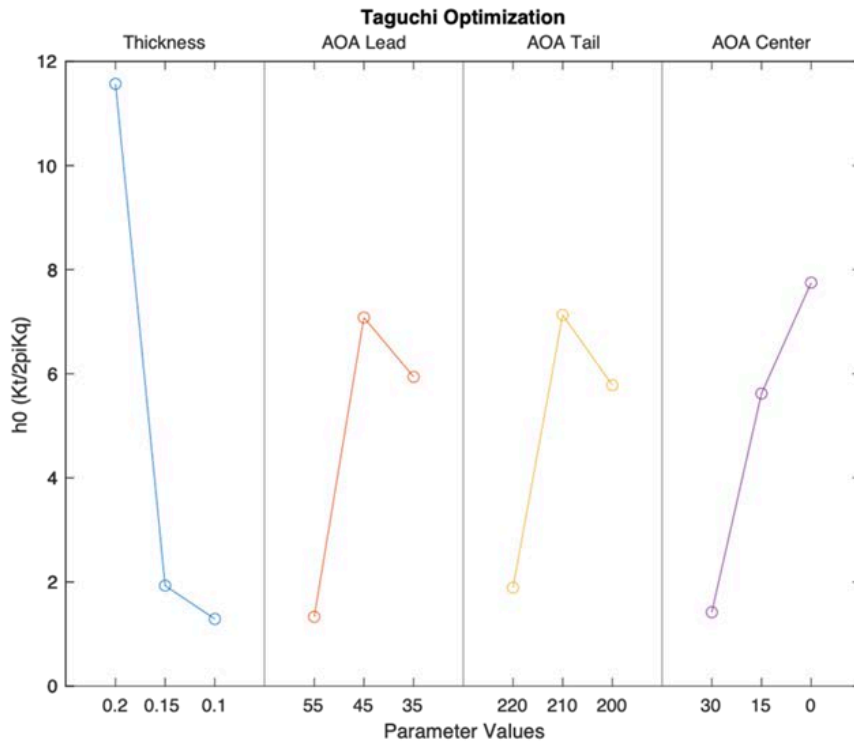

Round one results of Taguchi Method optimization examining four parameters with three levels of values each.

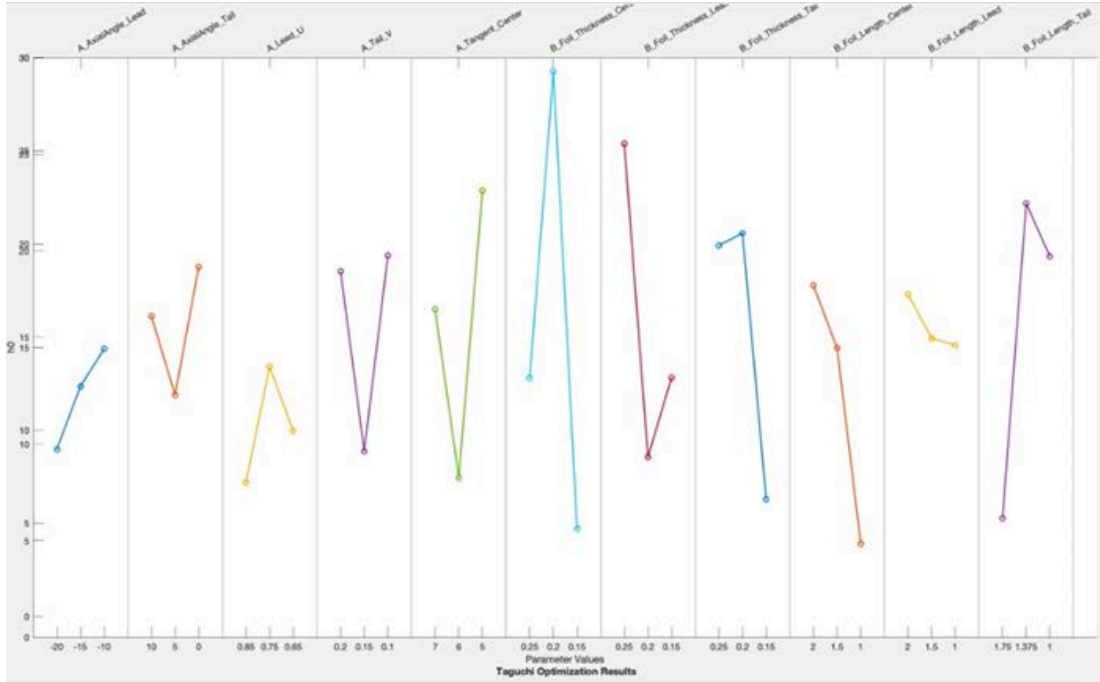

Round two results of Taguchi Method optimization examining eleven parameters with three levels of values.